



# SANYO Semiconductors

## DATA SHEET

### Thick-Film Hybrid IC

## STK433-000N-E series 2-4ch class-AB Audio Power IC from 40W to 150W

### Overview

The STK433-000N-E series is a hybrid IC designed to be used in from 40W to 150W x 2,3,4ch class AB audio power amplifiers.

### Application

- Audio Power amplifiers

### Features

- Pin-to-pin compatible outputs ranging from 40W to 150W.
- Miniature package.
- Output load impedance:  $R_L=6\Omega$  recommended.
- Allowable load shorted time: 0.3 second
- Allows the use of predesigned applications for standby and mute circuit.

### Series model

	STK433-040N-E	STK433-060N-E	STK433-130N-E	STK433-330N-E
Output1 (10%/1kHz)	40W x 2ch	50W x 2ch	150W x 2ch	150W x 3ch
Output2 (0.4%/20Hz-20kHz)	25W x 2ch	35W x 2ch	100W x 2ch	100W x 3ch
Maxi. rating Vcc (quiescent)	$\pm 38V$	$\pm 46V$	$\pm 71.5V$	$\pm 71.5V$
Max. rating Vcc (6 $\Omega$ )	$\pm 36V$	$\pm 40V$	$\pm 63V$	$\pm 63V$
Recommended operating Vcc (6 $\Omega$ )	$\pm 24V$	$\pm 27V$	$\pm 44V$	$\pm 44V$
Dimensions (excluding pin height)	47.0x25.6x9.0mm		67.0x25.6x9.0mm	64.0x36.6x9.0mm

	STK433-840N-E	STK433-870N-E	STK433-890N-E
Output1 (10%/1kHz)	40W x 4ch	60W x 4ch	80W x 4ch
Output2 (0.4%/20Hz-20kHz)	25W x 4ch	40W x 4ch	50W x 4ch
Maxi. rating Vcc (quiescent)	$\pm 38V$	$\pm 50V$	$\pm 54V$
Max. rating Vcc (6 $\Omega$ )	$\pm 36V$	$\pm 44V$	$\pm 47V$
Recommended operating Vcc (6 $\Omega$ )	$\pm 25V$	$\pm 30V$	$\pm 34V$
Dimensions (excluding pin height)	64.0x31.1x9.0mm		78.0x44.1x9.0mm

# STK433-000N-E series

## Package Dimensions (unit : mm typ)

### RoHS DIRECTIVE PASS

#### STK433-040N-E/060N-E

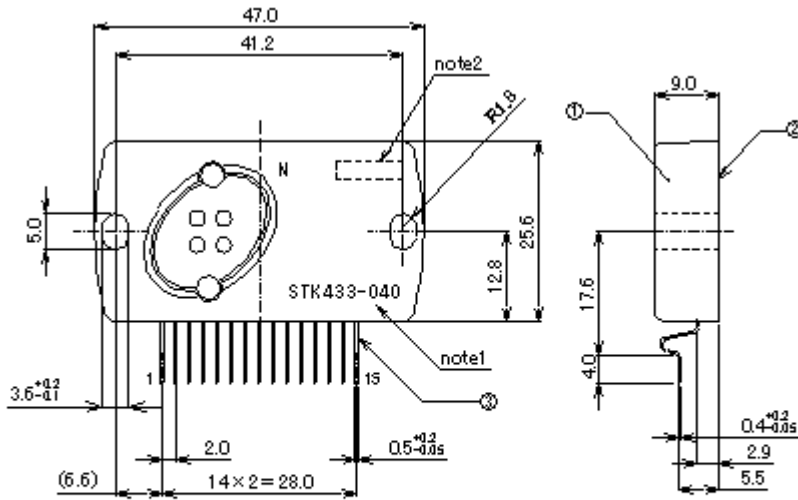

note1 : This indicates the Product name.  
The form of a character in this drawing differs from that of H-IC.  
note2: This indicates the Date code.

#### STK433-130N-E

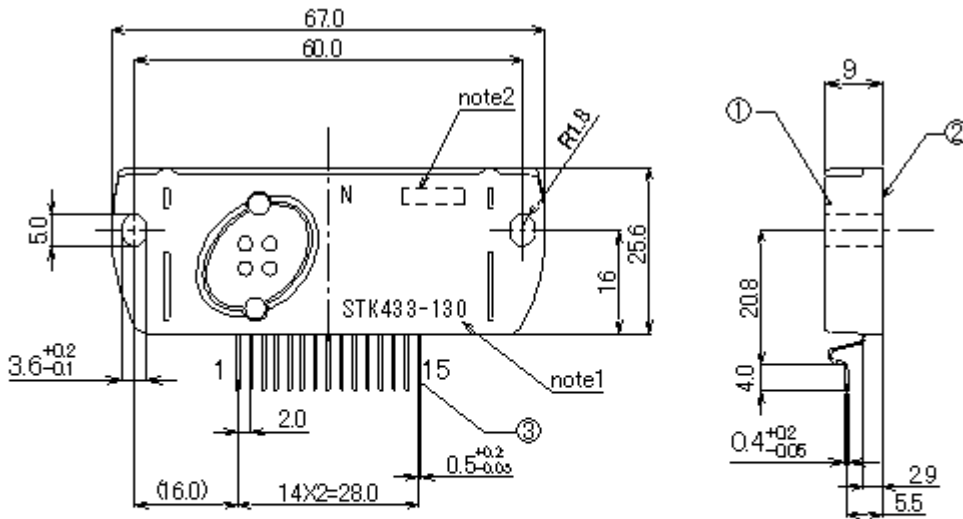

note1 : This indicates the Product name.  
The form of a character in this drawing differs from that of H-IC.  
note2: This indicates the Date code.  
The character specification (including the font, etc.) in this drawing differs from that of H-IC.

## STK433-000N-E series

### Package Dimensions (unit : mm typ)

#### RoHS DIRECTIVE PASS

#### STK433-330N-E

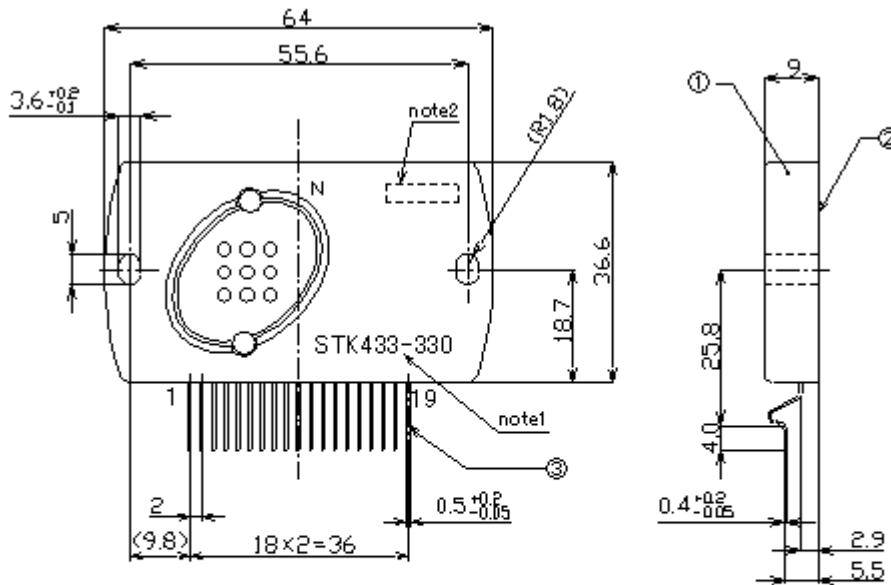

note1 : This indicates the Product name.  
The form of a character in this drawing differs from that of H-IC.

note2 : This indicates the Date code.  
The character specification (including the font, etc.) in this drawing differs from that of H-IC.

#### STK433-840N-E

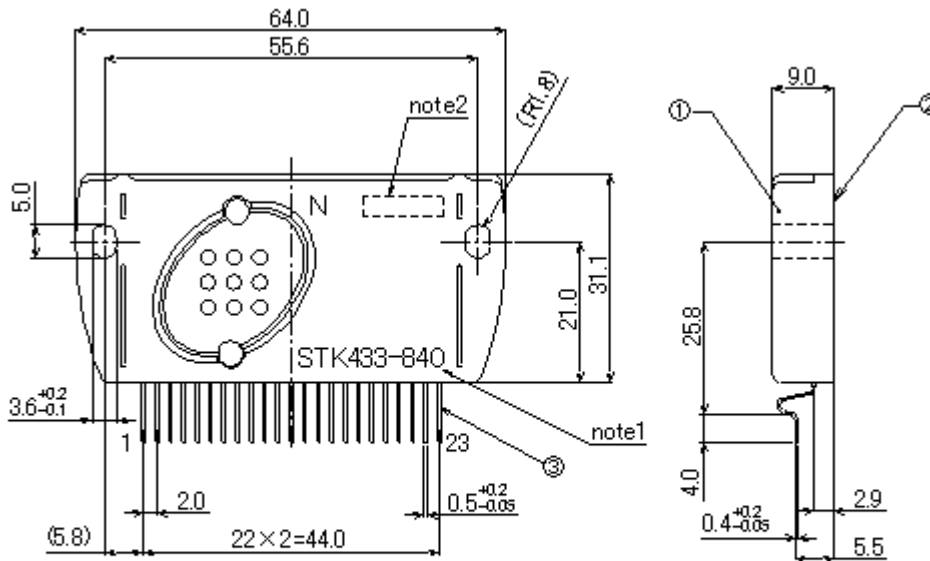

note1 : This indicates the Product name.  
The form of a character in this drawing differs from that of H-IC.

note2 : This indicates the Date code.

# STK433-000N-E series

Package Dimensions (unit : mm typ)

RoHS DIRECTIVE PASS

STK433-890N-E

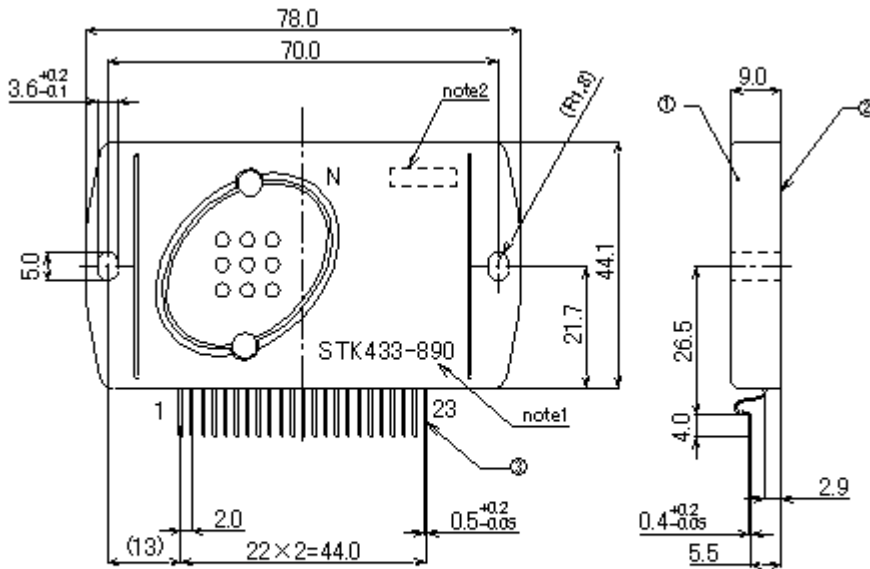

note1 : This indicates the Product name.  
The form of a character in this drawing differs from that of H-C.  
note2 : This indicates the Date code.

**STK433-000N-E series**

[STK433-000N/-100N/-300N sr Pin Layout]

	1	2	3	4	5	6	7	8	9	10	11	12	13	14	15
(Size)47.0*25.6*9.0	<b>2ch classAB/2.00mm</b>														
STK433-040N 40W/JEITA	-	-	+	O	O	O	O	+			I	N	S	N	I
STK433-060N 50W/JEITA	P	V	V	U	U	U	U	P	S	G	N	N	T	N	I
	R	c	c	T	T	T	T	R	U	N	/	F	A	F	N
	E	c	c	/	/	/	/	E	B	D	/	/	N	/	/
				C	C	C	C				C	C	D	C	C
(Size)67.0*25.6*9.0				H	H	H	H				H	H	-	H	H
STK433-130N 150W/JEITA				1	1	2	2				1	1	-	2	2
				+	-	+	-						Y		

	1	2	3	4	5	6	7	8	9	10	11	12	13	14	15	16	17	18	19
(Size)64.0*36.6*9.0	<b>3ch classAB/2.00mm</b>																		
STK433-330N 150W/JEITA	-	-	+	O	O	O	O	+			I	N	S	N	I	I	N	O	O
	P	V	V	U	U	U	U	P	S	G	N	N	T	N	I	N	F	U	U
	R	c	c	T	T	T	T	R	U	N	/	F	A	F	/	/	T	T	T
	E	c	c	/	/	/	/	E	B	D	C	C	N	/	C	C	/	/	/
				C	C	C	C				H	H	D	C	H	H	C	C	C
				H	H	H	H				1	1	-	H	H	3	3	3	3
				1	1	2	2						Y				+	+	-
				+	-	+	-												

[STK433-000N/-100N/-800Nsr Pin Layout]

	1	2	3	4	5	6	7	8	9	10	11	12	13	14	15
(Size)47.0*25.6*9.0	<b>2ch classAB/2.00mm</b>														
STK433-040N 40W/JEITA	-	-	+	O	O	O	O	+			I	N	S	N	I
STK433-060N 50W/JEITA	P	V	V	U	U	U	U	P	S	G	N	N	T	N	I
	R	c	c	T	T	T	T	R	U	N	/	F	A	F	N
	E	c	c	/	/	/	/	E	B	D	C	C	N	/	C
				C	C	C	C				H	H	D	C	C
(Size)67.0*25.6*9.0				H	H	H	H				H	H	-	H	H
STK433-130N 150W/JEITA				1	1	2	2				1	1	-	2	2
				+	-	+	-						Y		

	1	2	3	4	5	6	7	8	9	10	11	12	13	14	15	16	17	18	19	20	21	22	23
(Size)64.0*31.1*9.0	<b>4ch classAB/2.00mm</b>																						
STK433-840N 40W/JEITA	-	-	+	O	O	O	O	+			I	N	S	N	I	I	N	I	N	O	O	O	O
	P	V	V	U	U	U	U	P	S	G	N	N	T	N	I	N	F	I	N	U	U	U	U
	R	c	c	T	T	T	T	R	U	N	/	F	A	F	/	/	C	/	/	T	T	T	T
	E	c	c	/	/	/	/	E	B	D	C	C	N	/	C	C	H	C	C	/	/	/	/
				C	C	C	C				H	H	D	C	H	H	1	2	3	H	H	H	H
(Size)78.0*44.1*9.0				H	H	H	H				1	1	-	H	H	2	3	4	4	3	3	4	4
STK433-890N 80W/JEITA				1	1	2	2						Y							-	+	-	+
				+	-	+	-																

Equivalent Circuit

STK433-040N-E/060N-E

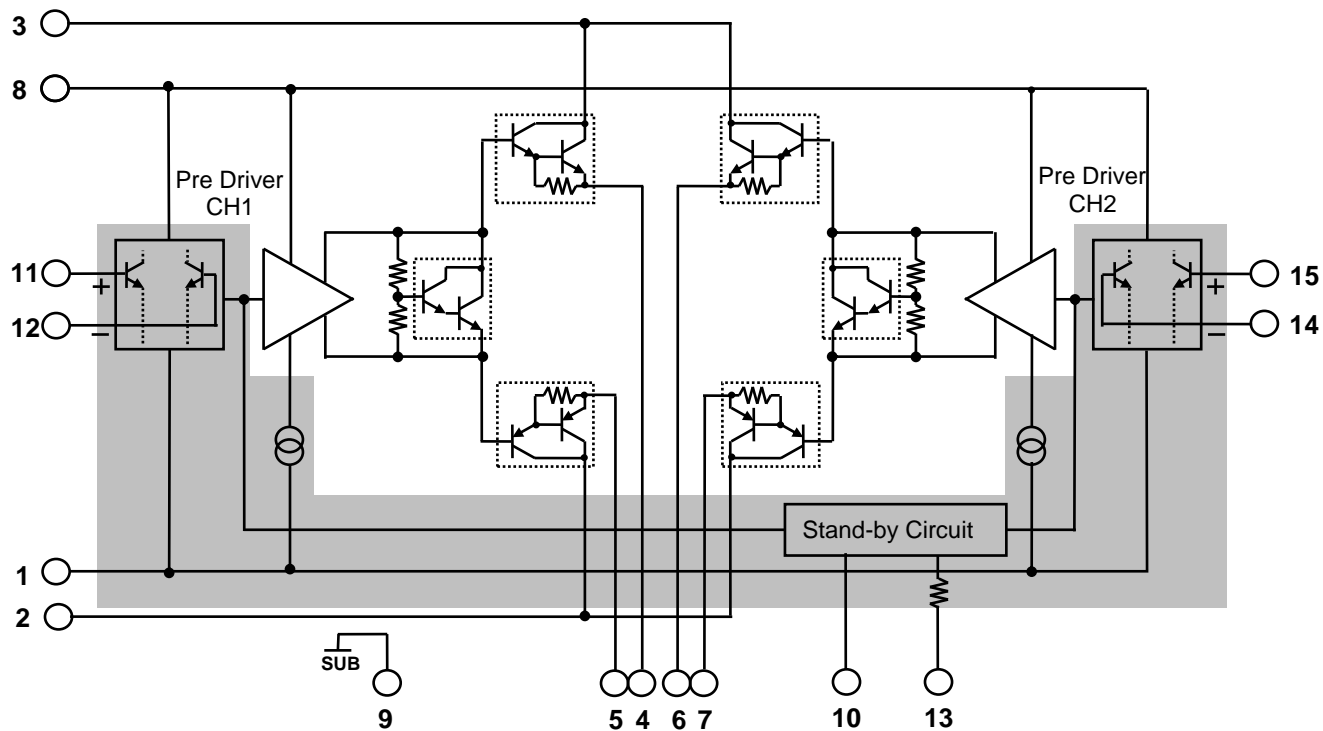

STK433-130N-E

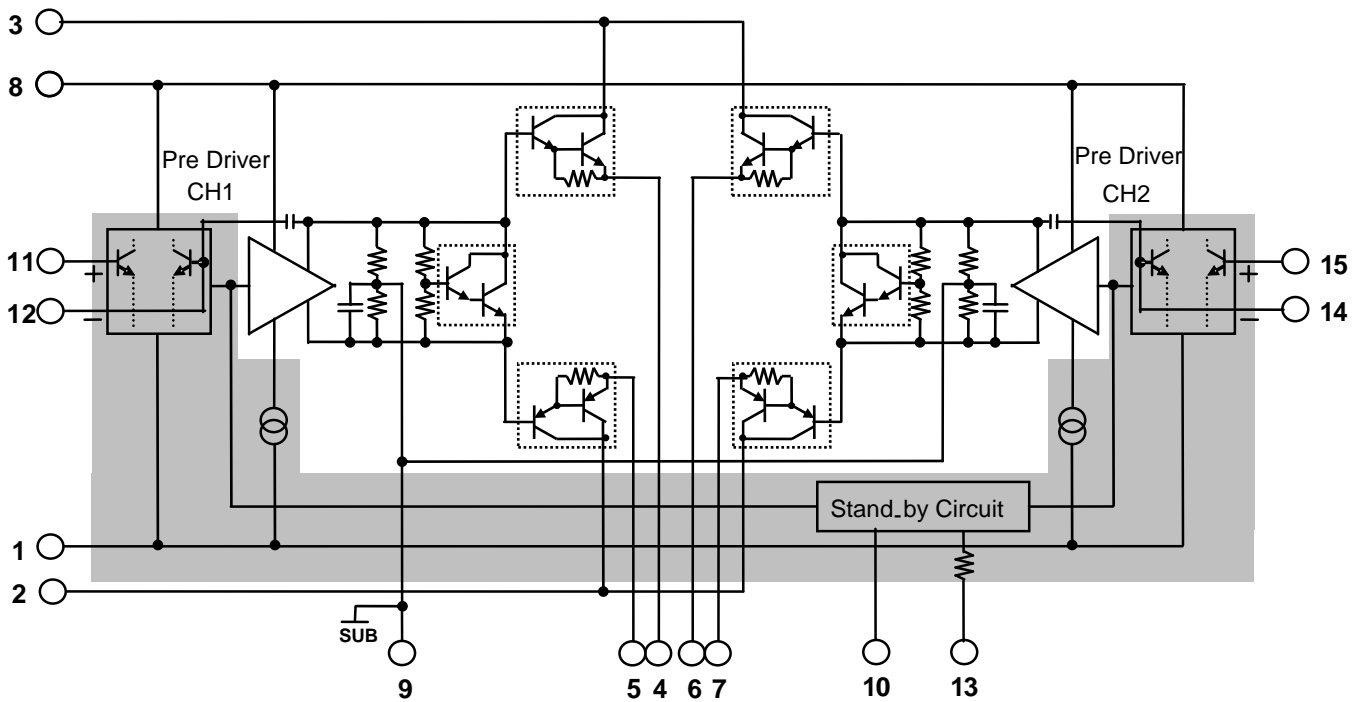

Equivalent Circuit

STK433-330N-E

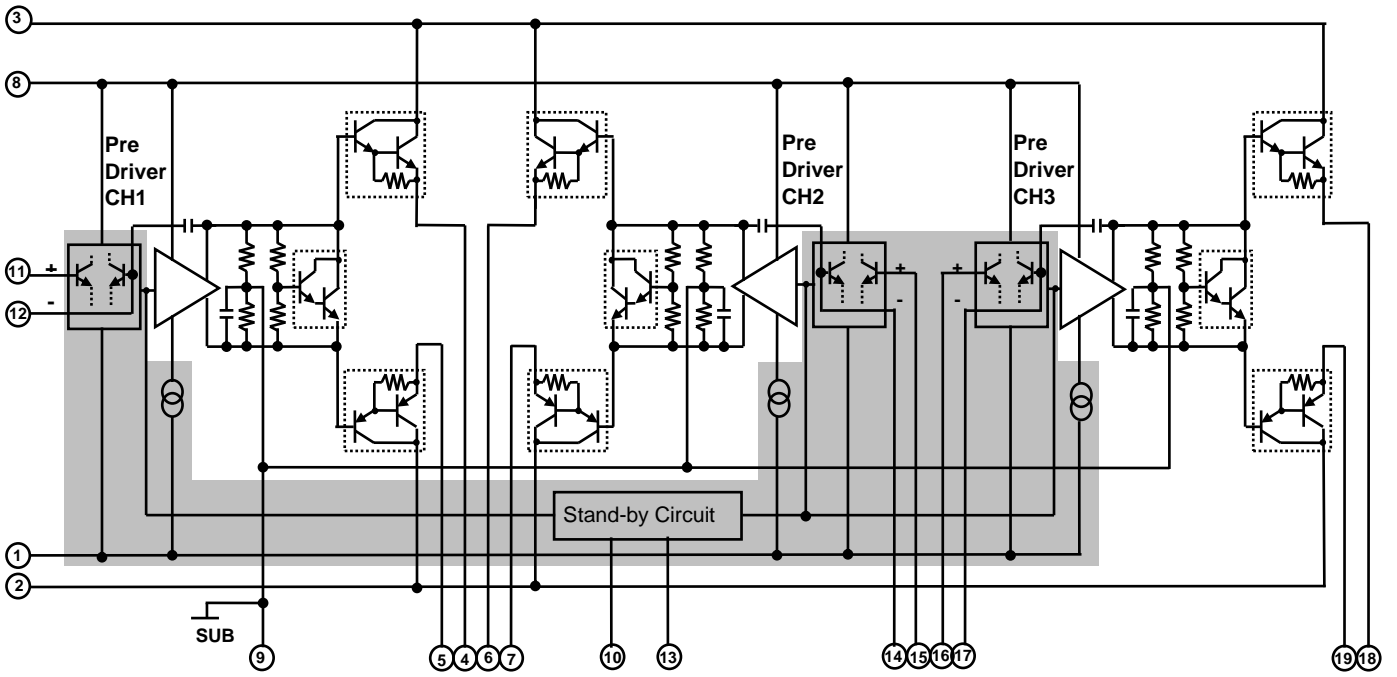

STK433-840N-E/890N-E

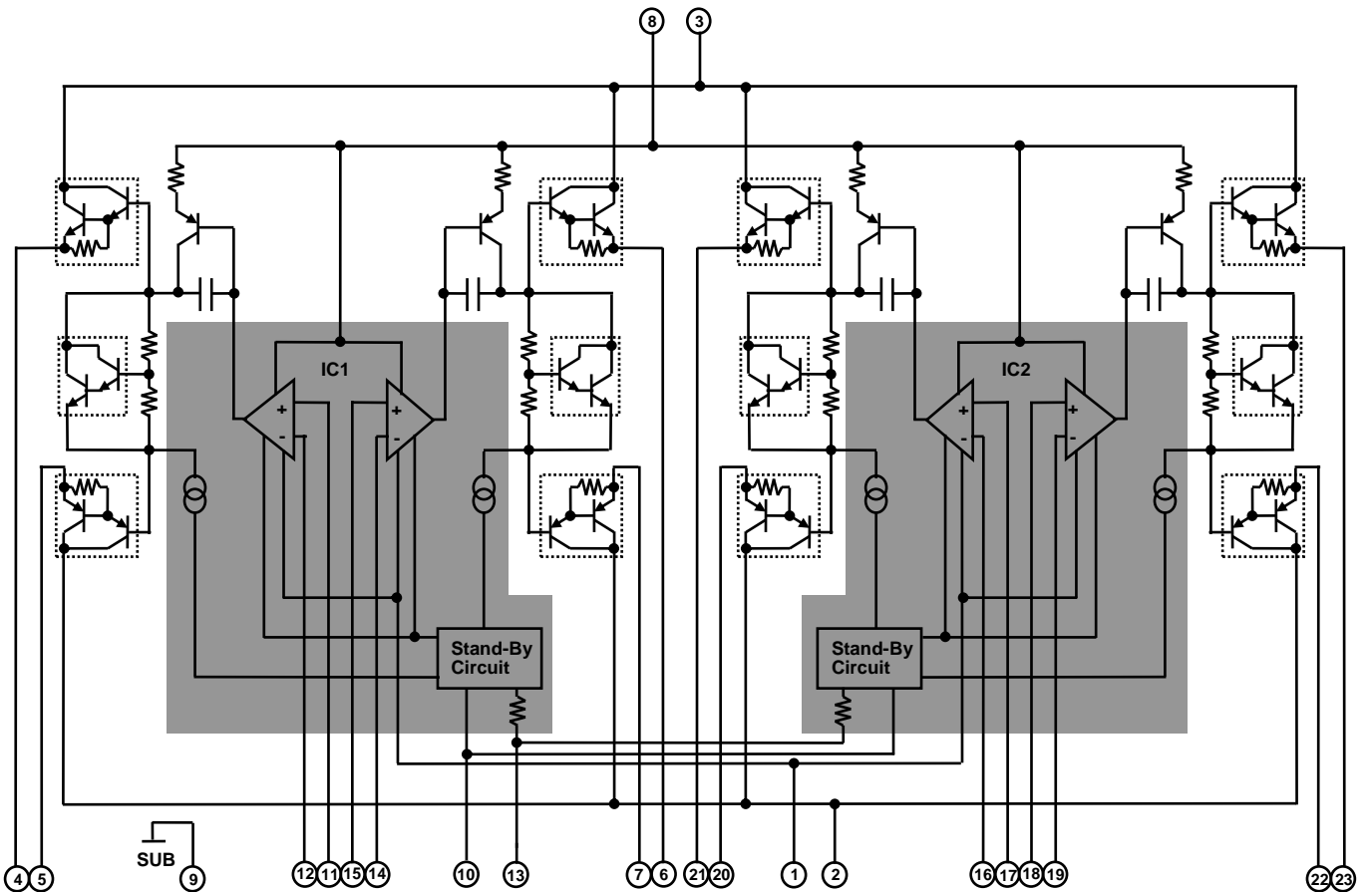

# STK433-000N-E series

STK433-040N-E

## Specifications

**Absolute maximum ratings** at Ta=25°C, Tc=25°C unless otherwise specified

Parameter	Symbol	Conditions	Ratings	Unit
Maximum Power Supply Voltage	Vcc max(0)	Non- signal	±38	V
Maximum Power Supply Voltage	Vcc max(1)	Signal, RL≥6Ω	±36	V
Maximum Power Supply Voltage	Vcc max(2)	Signal, RL=4Ω	±30	V
Minimum Operation Supply Voltage	Vcc min		±10	V
#13 Operating Voltage *5	VST OFF max	#13 voltage	-0.3 to +5.5	V
Thermal Resistance	Θj-c	Per one power transistor	4.2	°C/W
Junction Temperature	Tj max	Should satisfy Tj max and Tc max	150	°C
Operating Substrate Temperature	Tc max		125	°C
Storage Temperature	Tstg		-30 to +125	°C
Allowable Time for Load Short-circuit *4	ts	Vcc=±24V, RL=6Ω, f=50Hz Po=25W, 1ch drive	0.3	s

**Operating Characteristics** at Tc=25°C, RL=6Ω (Non-inductive Load), Rg=600Ω, VG=30dB

Parameter	Symbol	Conditions *2				Ratings			Unit	
		Vcc [V]	f [Hz]	Po [W]	THD [%]	min	typ	max		
Output Power *1	Po 1	±24	20 to 20k		0.4	23	25		W	
	Po 2	±24	1k		10		40			
	Po 3	±20	1k		1	RL=4Ω	25			
THD *1	THD 1	±24	20 to 20k	5.0	VG=30dB			0.4	%	
	THD 2	±24	1k			0.02				
Frequency Characteristics *1	fL, fH	±24		1.0		+0 -3dB	20 to 50k		Hz	
Input Impedance	ri	±24	1k	1.0			55		kΩ	
Output Noise Voltage *3	VNO	±29				Rg=2.2kΩ		1.0	mVrms	
Quiescent Current	Icco	±29				No load	15	30	70	mA
Quiescent Current at Stand-by	ICST	±29							1.0	mA
Output Neutral Voltage	VN	±29					-70	0	+70	mV
#13 Stand-By ON Threshold *5	VST ON	±24				Stand-by		0	0.6	V
#13 Stand-By OFF Threshold *5	VST OFF	±24				Operation	2.5	3.0	5.5	V

### Note

- \*1. 1 channel Operation.
- \*2. All tests are measured using a constant-voltage supply unless otherwise specified
- \*3. The output noise voltage is peak value of an average-reading meter with a rms value scale (VTVM).  
A regulated AC supply (50Hz) should be used to eliminate the effects of AC primary line flicker noise
- \*4. Allowable time for load short-circuit and output noise voltage are measured using the specified transformer power supply.
- \*5. Please connect - PreVcc pin (#1 pin) with the stable minimum voltage.  
and connect so that current does not flow in by reverse bias.
- \*6. In case of heat sink design, we request customer to design in the condition to have assumed market.
- \* The case of this Hybrid-IC is using thermosetting silicon adhesive(TSE322SX).
- \* Weight of HIC : (typ) 12.0 g  
Outer carton dimensions (W×L×H) : 452mm×325mm×192mm

Specified Transformer Power Supply  
(Equivalent to MG-200)

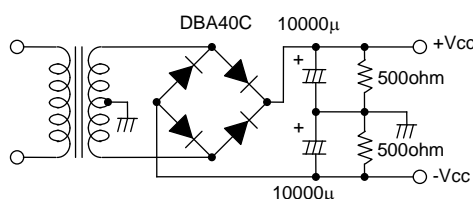



# STK433-000N-E series

## STK433-060N-E Specifications

**Absolute maximum ratings** at Ta=25°C, Tc=25°C unless otherwise specified

Parameter	Symbol	Conditions	Ratings	Unit
Maximum Power Supply Voltage	Vcc max(0)	Non- signal	±46	V
Maximum Power Supply Voltage	Vcc max(1)	Signal, RL≥6Ω	±40	V
Maximum Power Supply Voltage	Vcc max(2)	Signal, RL=4Ω	±33	V
Minimum Operation Supply Voltage	Vcc min		±10	V
#13 Operating Voltage *5	VST OFF max	#13 voltage	-0.3 to +5.5	V
Thermal Resistance	Θj-c	Per one power transistor	3.5	°C/W
Junction Temperature	Tj max	Should satisfy Tj max and Tc max	150	°C
Operating Substrate Temperature	Tc max		125	°C
Storage Temperature	Tstg		-30 to +125	°C
Allowable Time for Load Short-circuit *4	ts	Vcc=±27V, RL=6Ω, f=50Hz Po=35W, 1ch drive	0.3	s

**Operating Characteristics** at Tc=25°C, RL=6Ω(Non-inductive Load), Rg=600Ω, VG=30dB

Parameter	Symbol	Conditions *2				Ratings			Unit	
		Vcc [V]	f [Hz]	Po [W]	THD [%]	min	typ	max		
Output Power *1	Po 1	±27	20 to 20k		0.4	33	35		W	
	Po 2	±27	1k		10		50			
	Po 3	±22	1k		1	RL=4Ω	35			
THD *1	THD 1	±27	20 to 20k	5.0	VG=30dB			0.4	%	
	THD 2	±27	1k			0.02				
Frequency Characteristics *1	fL, fH	±27		1.0		+0 -3dB	20 to 50k		Hz	
Input Impedance	ri	±27	1k	1.0			55		kΩ	
Output Noise Voltage *3	VNO	±33				Rg=2.2kΩ		1.0	mVrms	
Quiescent Current	Icco	±33				No load	15	30	70	mA
Quiescent Current at Stand-by	ICST	±33				VST=0v			1.0	mA
Output Neutral Voltage	VN	±33					-70	0	+70	mV
#13 Stand-By ON Threshold *5	VST ON	±27				Stand-by		0	0.6	V
#13 Stand-By OFF Threshold *5	VST OFF	±27				Operation	2.5	3.0	5.5	V

### Note

- \*1. 1 channel Operation.
- \*2. All tests are measured using a constant-voltage supply unless otherwise specified
- \*3. The output noise voltage is peak value of an average-reading meter with a rms value scale (VTVM).  
A regulated AC supply (50Hz) should be used to eliminate the effects of AC primary line flicker noise
- \*4. Allowable time for load short-circuit and output noise voltage are measured using the specified transformer power supply.
- \*5. The impression voltage of '#13(Stand-By) pin' must not exceed the maximum rating.  
Power amplifier operate by impressing voltage +2.5 to +5.5v to '#13(Stand-By) pin'.
- \* Please connect - PreVcc pin (#1 pin) with the stable minimum voltage.  
and connect so that current does not flow in by reverse bias.
- \* In case of heat sink design, we request customer to design in the condition to have assumed market.
- \* The case of this Hybrid-IC is using thermosetting silicon adhesive(TSE322SX).
- \* Weight of HIC : (typ) 12.0 g  
Outer carton dimensions (W×L×H) : 452mm×325mm×192mm

Specified Transformer Power Supply  
(Equivalent to MG-200)

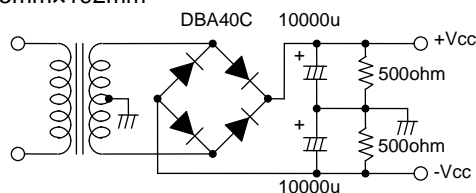

## STK433-000N-E series

STK433-130N-E

### Specifications

**Absolute maximum ratings** at Ta=25°C, Tc=25°C unless otherwise specified

Parameter	Symbol	Conditions	Ratings	Unit
Maximum Power Supply Voltage	Vcc max(0)	Non- signal	±71.5	V
Maximum Power Supply Voltage	Vcc max(1)	Signal, RL≥6Ω	±63	V
Maximum Operation Supply Voltage	Vcc min		±10	V
#13 Operating Voltage *5	VST OFF max		-0.3 to +5.5	V
Thermal Resistance	Θj-c	Per one power transistor	1.6	°C/W
Junction Temperature	Tj max	Should satisfy Tj max and Tc max	150	°C
Operating Substrate Temperature	Tc max		125	°C
Storage Temperature	Tstg		-30 to +125	°C
Allowable Time for Load Short-circuit *4	ts	Vcc=±44V,RL=6Ω,f=50Hz Po=100W,1ch drive	0.3	s

**Operating Characteristics** at Tc=25°C, RL=6Ω(Non-inductive Load), Rg=600Ω, VG=30dB

Parameter	Symbol	Conditions				Ratings			Unit	
		Vcc [V]	f [Hz]	Po [W]	THD [W]	min	typ	max		
Output Power *1	Po 1	±44	20 to 20k		0.4	96	100		W	
	Po 2	±44	1k		10		150			
THD *1	THD 1	±44	20 to 20k	5.0	VG=30dB			0.4	%	
	THD 2	±44	1k				0.01			
Frequency Characteristics *1	fL, fH	±44		1.0		+0 -3dB	20 to 50k		Hz	
Input Impedance	ri	±44	1k	1.0			55		kΩ	
Output Noise Voltage *3	VNO	±53				Rg=2.2kΩ		1.0	mVrms	
Quiescent Current	Icco	±53				No load	40	80	100	mA
Output Neutral Voltage	VN	±53					-70	0	+70	mV
#13 Stand-By ON Threshold *5	VST ON	±44				Stand-by		0	0.6	V
#13 Stand-By OFF Threshold *5	VST OFF	±44				Operation	2.5	3.0	5.5	V

### Note

\*1.1channel Operation.

\*2.All tests are measured using a constant-voltage supply unless otherwise specified

\*3.The output noise voltage is peak value of an average-reading meter with a rms value scale (VTVM).

A regulated AC supply (50Hz) should be used to eliminate the effects of AC primary line flicker noise

\*4.Allowable time for load short-circuit and output noise voltage are measured using the specified transformer power supply.

\*5. The impression voltage of '#13(Stand-By) pin' must not exceed the maximum rating.

Power amplifier operate by impressing voltage +2.5 to +5.5v to '#13(Stand-By) pin'.

\* Please connect - PreVcc pin (#1 pin)with the stable minimum voltage.

and connect so that current does not flow in by reverse bias.

\* In case of heat sink design, we request customer to design in the condition to have assumed market.

\* The case of this Hybrid-IC is using thermosetting silicon adhesive(TSE322SX).

\* Weight of HIC : (typ)18.4 g

Outer carton dimensions (WxLxH) : 429mmx245mmx275mm

Specified Transformer Power Supply  
(Equivalent to MG-250)

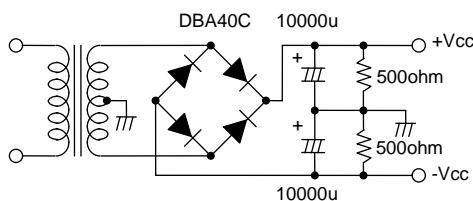

## STK433-000N-E series

STK433-330N-E

### Specifications

**Absolute maximum ratings** at Ta=25°C, Tc=25°C unless otherwise specified

Parameter	Symbol	Conditions	Ratings	Unit
Maximum Power Supply Voltage	Vcc max(0)	Non- signal	±71.5	V
Maximum Power Supply Voltage	Vcc max(1)	Signal, RL≥6Ω	±63	V
Maximum Operation Supply Voltage	Vcc min		±10	V
#13 Operating Voltage *5	VST OFF max		-0.3 to +5.5	V
Thermal Resistance	Θj-c	Per one power transistor	1.6	°C/W
Junction Temperature	Tj max	Should satisfy Tj max and Tc max	150	°C
Operating Substrate Temperature	Tc max		125	°C
Storage Temperature	Tstg		-30 to +125	°C
Allowable Time for Load Short-circuit *4	ts	Vcc=±44V,RL=6Ω,f=50Hz Po=100W,1ch drive	0.3	s

**Operating Characteristics** at Tc=25°C, RL=6Ω(Non-inductive Load), Rg=600Ω, VG=30dB

Parameter	Symbol	Conditions				Ratings			Unit	
		Vcc [V]	f [Hz]	Po [W]	THD [W]	min	typ	max		
Output Power *1	Po 1	±44	20 to 20k		0.4	96	100		W	
	Po 2	±44	1k		10		150			
THD *1	THD 1	±44	20 to 20k	5.0	VG=30dB			0.4	%	
	THD 2	±44	1k				0.01			
Frequency Characteristics *1	fL, fH	±44		1.0		+0 -3dB	20 to 50k		Hz	
Input Impedance	ri	±44	1k	1.0			55		kΩ	
Output Noise Voltage *3	VNO	±53				Rg=2.2kΩ		1.0	mVrms	
Quiescent Current	Icco	±53				No load	60	120	160	mA
Output Neutral Voltage	VN	±53					-70	0	+70	mV
#13 Stand-By ON Threshold *5	VST ON	±44				Stand-by		0	0.6	V
#13 Stand-By OFF Threshold *5	VST OFF	±44				Operation	2.5	3.0	5.5	V

### Note

\*1. 1channel Operation.

\*2. All tests are measured using a constant-voltage supply unless otherwise specified

\*3. The output noise voltage is peak value of an average-reading meter with a rms value scale (VTVM).

A regulated AC supply (50Hz) should be used to eliminate the effects of AC primary line flicker noise

\*4. Allowable time for load short-circuit and output noise voltage are measured using the specified transformer power supply.

\*5. The impression voltage of '#13(Stand-By)pin' must not exceed the maximum rating.

Power amplifier operate by impressing voltage +2.5 to +5.5v to '#13(Stand-By)pin'.

\* Please connect - PreVcc pin (#1 pin) with the stable minimum voltage.

and connect so that current does not flow in by reverse bias.

\* In case of heat sink design, we request customer to design in the condition to have assumed market.

\* The case of this Hybrid-IC is using thermosetting silicon adhesive(TSE322SX).

\* Weight of HIC : (typ)24.5g

Outer carton dimensions (WxLxH) : 452mmx325mmx192mm

Specified Transformer Power Supply  
(Equivalent to MG-250)

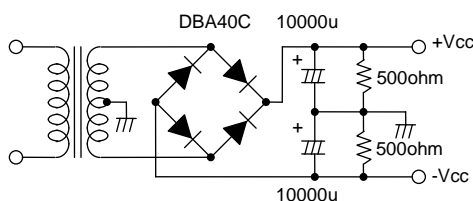

## STK433-000N-E series

STK433-840N-E

### Specifications

**Absolute maximum ratings** at Ta=25°C, Tc=25°C unless otherwise specified

Parameter	Symbol	Conditions	Ratings	Unit
Maximum supply voltage	Vcc max(0)	No signal	±38	V
	Vcc max(1)	Signal, RL≥6Ω	±36	V
	Vcc max(2)	Signal, RL=4Ω	±30	V
Minimum supply voltage	Vcc min		±10	V
#13pin Operating Voltage *5	VST OFF max	#13pin voltage	-0.3 to +5.5	V
Thermal resistance	Θj-c	Per power transistor	4.2	°C/W
Junction temperature	Tj max	Both the Tj max and Tc max conditions must be met.	150	°C
Operating Substrate Temperature	Tc max		125	°C
Storage temperature	Tstg		-30 to +125	°C
Allowable load shorted time *4	ts	Vcc=±25V, RL=6Ω, f=50Hz Po=25W, 1ch Drive	0.3	s

**Operating Characteristics** at Tc=25°C, RL=6Ω(Non-inductive Load), Rg=600Ω, VG=30dB

Parameter	Symbol	Conditions *2				Ratings			Unit	
		Vcc [V]	f [Hz]	Po [W]	THD [%]	min	typ	max		
Output power *1	Po 1	±25	20 to 20k		0.6	23	25		W	
	Po 2	±25	1k		10		40			
THD *1	THD 1	±25	20 to 20k	5.0		VG=30dB		0.6	%	
	THD 2	±25	1k					0.02		
Frequency characteristics *1	fL, fH	±25		1.0		+0 -3dB	20 to 50k		Hz	
Input impedance	Ri	±25	1k	1.0			55		kΩ	
Output noise voltage *3	VNO	±30				Rg=2.2 kΩ		1.0	mVrms	
Quiescent current	Icco	±30				No load	30	60	140	mA
Quiescent Current at Stand-by	ICST	±30				VST=0v			1.0	mA
Neutral voltage	VN	±30					-70	0	+70	mV
#13 Stand-By ON Threshold *5	VST ON	±25				Stand-by		0	0.6	V
#13 Stand-By OFF Threshold *5	VST OFF	±25				Operation	2.5	3.0	5.5	V

[Note]

\*1. 1channel Operation.

\*2. All tests are measured using a constant-voltage supply unless otherwise specified

\*3. The output noise voltage is peak value of an average-reading meter with a rms value scale (VTVM).

A regulated AC supply (50Hz) should be used to eliminate the effects of AC primary line flicker noise

\*4. Allowable time for load short-circuit and output noise voltage are measured using the specified transformer power supply.

\*5. The impression voltage of '#13(Stand-By)pin' must not exceed the maximum rating.

Power amplifier operate by impressing voltage +2.5 to +5.5V to '#13(Stand-By) pin'.

\* Please connect - PreVcc pin (#1 pin) with the stable minimum voltage and connect so that current does not flow in by reverse bias.

\* In case of heat sink design, we request customer to design in the condition to have assumed market.

\* The case of this Hybrid-IC is using thermosetting silicon adhesive(TSE322SX).

\* Weight of 1 HIC : (typ) 20.6 g

Outer carton dimensions (W×L×H) : 502mm×247mm×282mm

Specified Transformer Power Supply

(Equivalent to MG-200)

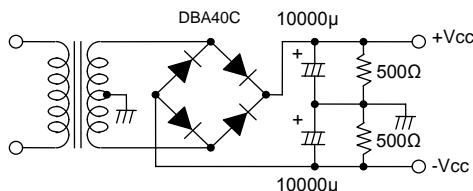

# STK433-000N-E series

## STK433-890N-E Specifications

**Absolute maximum ratings** at Ta=25°C, Tc=25°C unless otherwise specified

Parameter	Symbol	Conditions	Ratings	Unit
Maximum supply voltage	Vcc max(0)	No signal	±54	V
	Vcc max(1)	Signal, RL≥6Ω	±47	V
	Vcc max(2)	Signal, RL=4Ω	±40	V
Minimum supply voltage	Vcc min		±10	V
#13pin Operating Voltage *5	VST OFF max	#13pin voltage	-0.3 to +5.5	V
Thermal resistance	Θj-c	Per power transistor	2.1	°C/W
Junction temperature	Tj max	Both the Tj max and Tc max conditions must be met.	150	°C
Operating Substrate Temperature	Tc max		125	°C
Storage temperature	Tstg		-30 to +125	°C
Allowable load shorted time *4	ts	Vcc=±34V, RL=6Ω, f=50Hz Po=50W, 1ch Drive	0.3	s

**Operating Characteristics** at Tc=25°C, RL=6Ω(Non-inductive Load), Rg=600Ω, VG=30dB

Parameter	Symbol	Conditions *2				Ratings			Unit
		Vcc [V]	f [Hz]	Po [W]	THD [%]	min	typ	max	
Output power *1	Po 1	±34	20 to 20k		0.6	47	50		W
	Po 2	±34	1k		10		80		
THD *1	THD 1	±34	20 to 20k	5.0	VG=30dB			0.6	%
	THD 2	±34	1k				0.02		
Frequency characteristics *1	fL, fH	±34		1.0	+0 -3dB	20 to 50k			Hz
Input impedance	ri	±34	1k	1.0			55		kΩ
Output noise voltage *3	VNO	±40			Rg=2.2 kΩ			1.0	mVrms
Quiescent current	Icco	±40			No load	90	150	210	mA
Quiescent Current at Stand-by	ICST	±40			VST=0v			1.0	mA
Neutral voltage	VN	±40				-70	0	+70	mV
#13 Stand-By ON Threshold *5	VST ON	±34			Stand-by		0	0.6	V
#13 Stand-By OFF Threshold *5	VST OFF	±34			Operation	2.5	3.0	5.5	V

[Note]

- \*1. 1channel Operation.
- \*2. All tests are measured using a constant-voltage supply unless otherwise specified
- \*3. The output noise voltage is peak value of an average-reading meter with a rms value scale (VTVM).  
A regulated AC supply (50Hz) should be used to eliminate the effects of AC primary line flicker noise
- \*4. Allowable time for load short-circuit and output noise voltage are measured using the specified transformer power supply.
- \*5. The impression voltage of '#13(Stand-By)pin' must not exceed the maximum rating.  
Power amplifier operate by impressing voltage +2.5 to +5.5V to '#13(Stand-By) pin'.
- \* Please connect : PreVcc pin (#1 pin)with the stable minimum voltage and connect so that current does not flow in by reverse bias.
- \* In case of heat sink design, we request customer to design in the condition to have assumed market.
- \* The case of this Hybrid-IC is using thermosetting silicon adhesive(TSE322SX).
- \* Weight of 1 HIC : (typ) 37.0 g  
Outer carton dimensions (W×L×H) : 452mm×325mm×192mm

Specified Transformer Power Supply  
(Equivalent to MG-200)

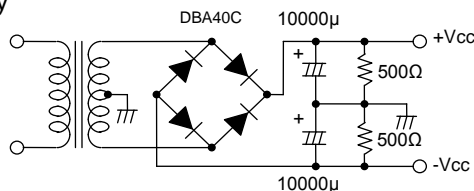

# STK433-000N-E series

## Application Circuit

STK433-040N-E/060N-E/130N-E

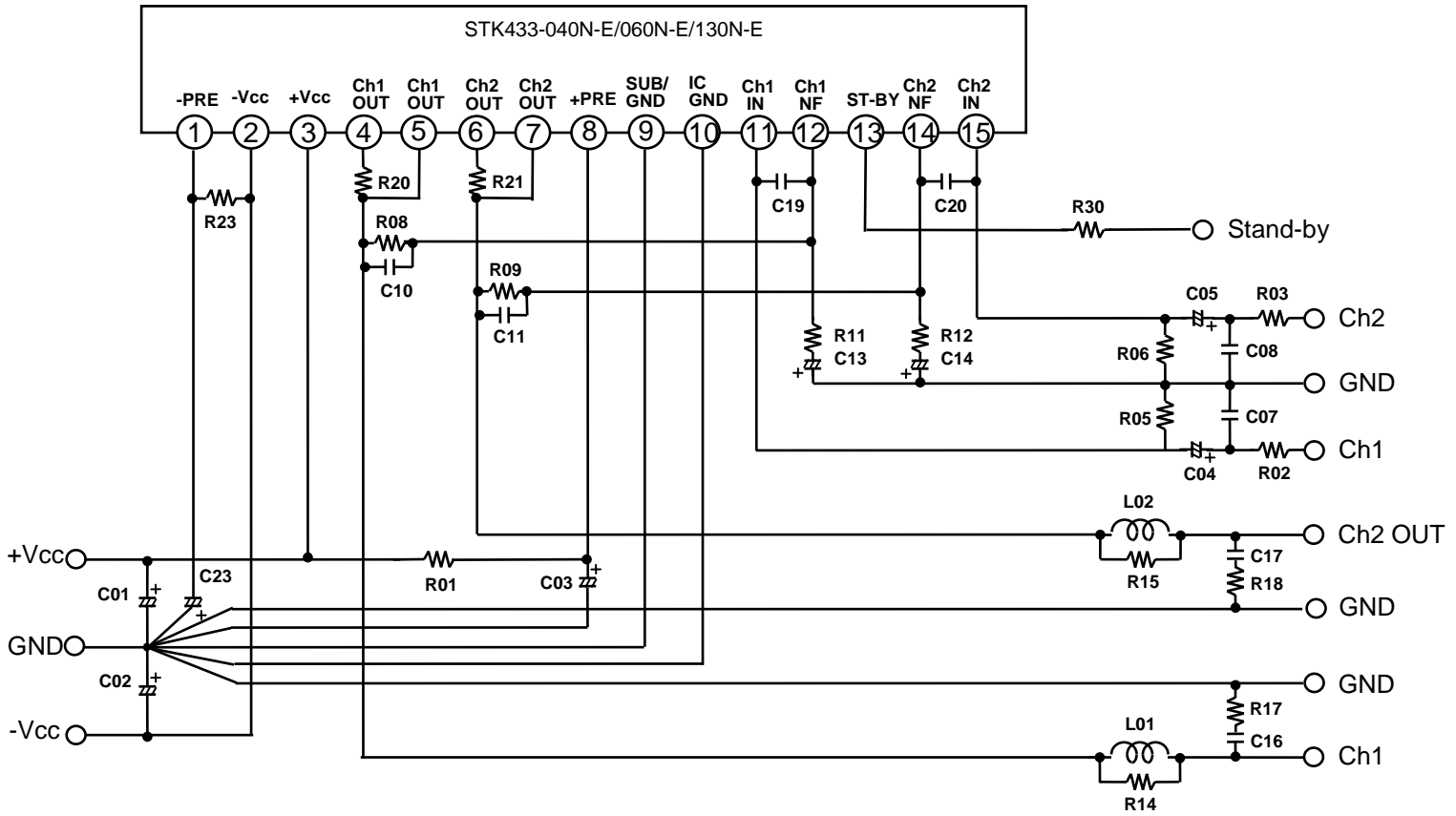

Application Circuit

STK433-330N-E

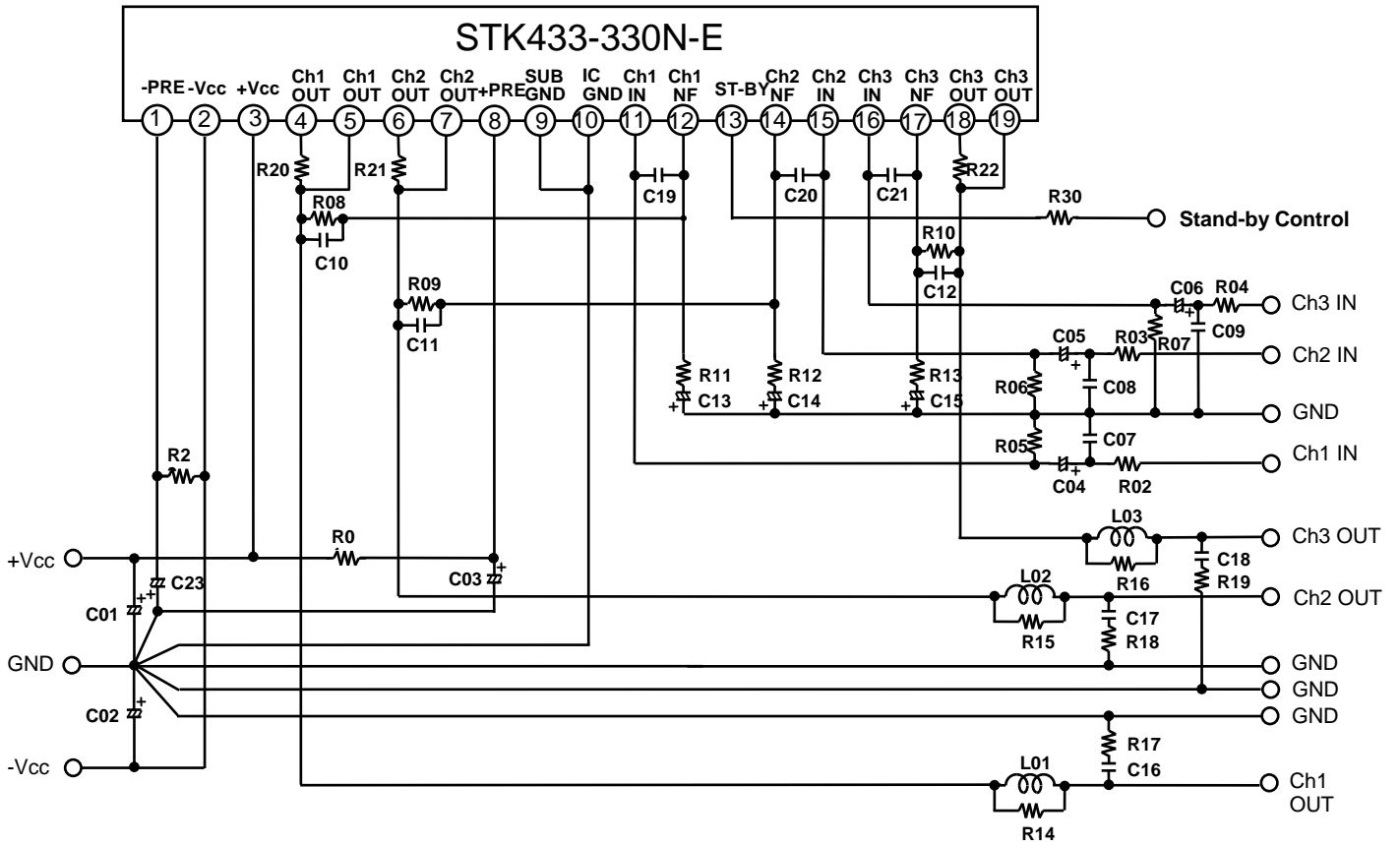

# STK433-000N-E series

## Application Circuit

STK433-840N-E/890N-E

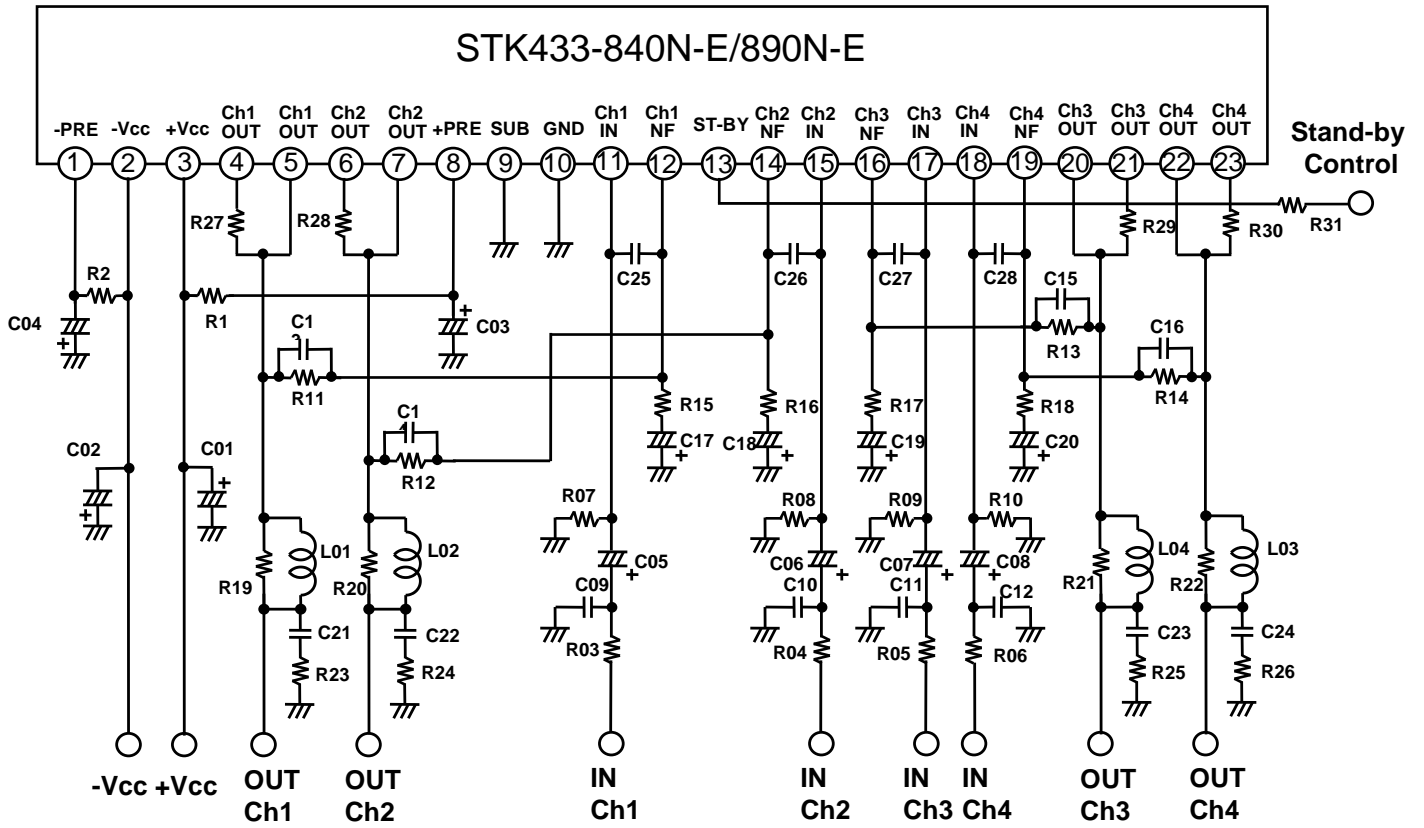



PCB Layout example

STK433-040N-E/060N-E/130N-E/330N-E

Top view

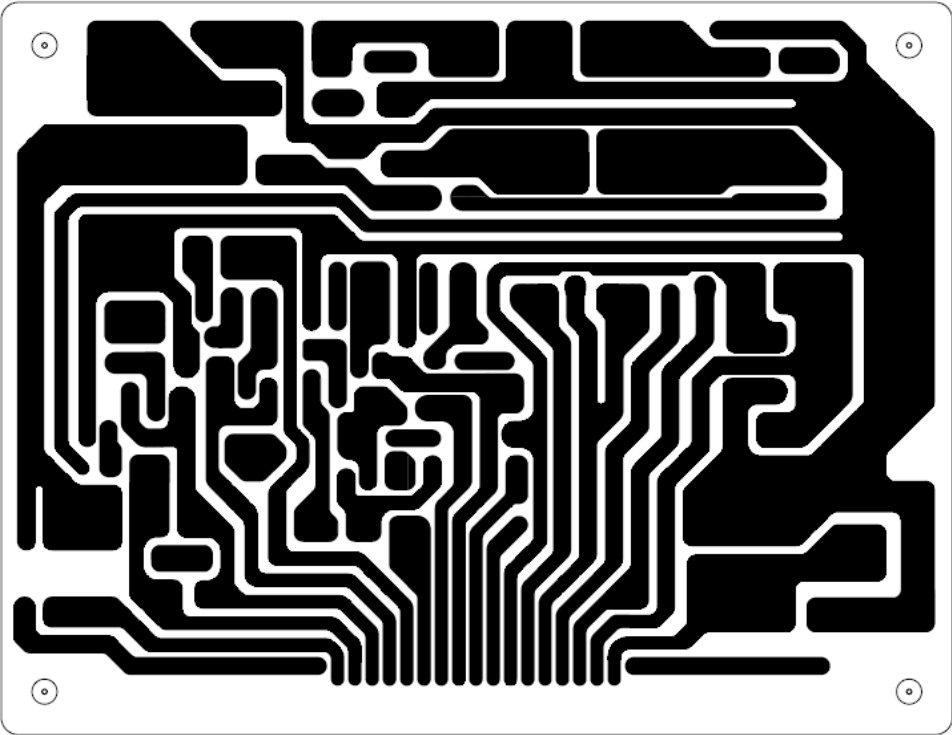
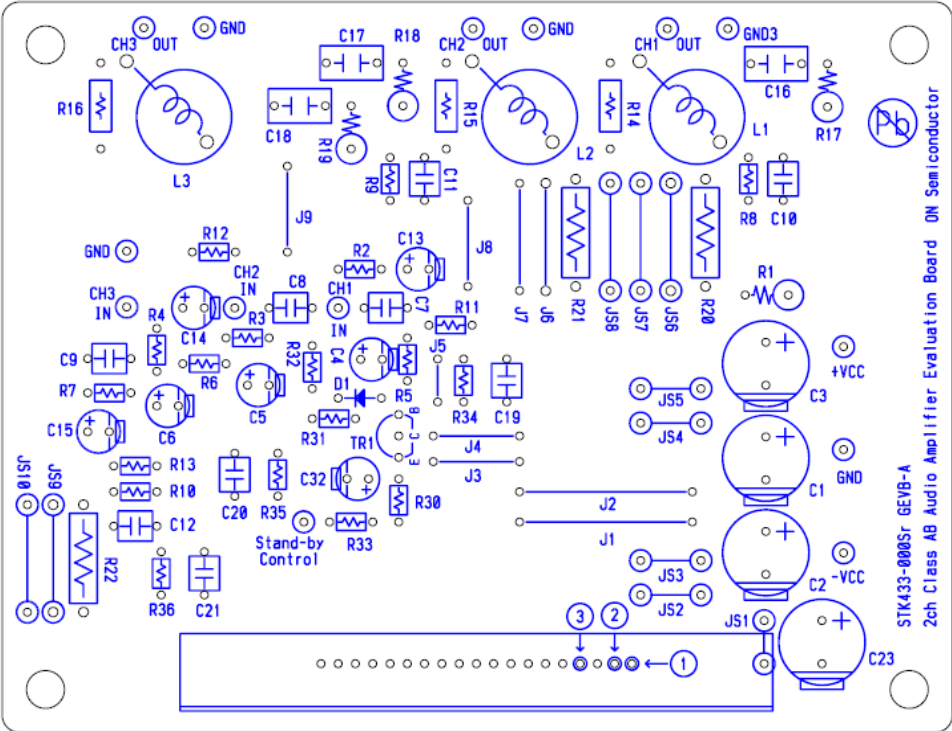

**STK433-040N-E/060N-E/130N-E/330N-E PCB PARTS LIST**

PCB Name : STK433 - 000Sr GEVB - A

Location No.  (*2) 2ch Amp doesn't mount parts of( )	RATING	Component		
		STK433-		
	-	040N-E	060N-E	130N-E/ 330N-E
R01	100Ω,1W	○		
R02,R03,(R04)	1kΩ,1/6W	○		
R05,R06,(R07),R08,R09,(R10)	56kΩ,1/6W	○		
R11,R12,(R13)	1.8kΩ,1/6W	○		
R14,R15,(R16)	4.7Ω,1/4W	○		
R17,R18,(R19)	4.7Ω,1W	○		
R20,R21,(R22)	0.22Ω,5W	○		
C01,C02,C03,C23	100μF,100V	○		
C04,C05,(C06)	2.2μF,50V	○		
C07,C08,(C09)	470pF,50V	○		
C10,C11,(C12)	3pF,50V	○		
C13,C14,(C15)	10μF,10V	○		
C16,C17,(C18)	0.1μF,50V	○		
C19,C20,(C21)	***pF,50V	100pF	56pF	N.C.
R34,R35,(R36)	3kΩ,1/6W	Short		
L01,L02,(L03)	3μH	○		
Stand-By Control Circuit	Tr1	Vce≥75V,Ic≥1mA		
	D1	Di		
	R30 (*2)	***kΩ,1/6W		
	R31	33kΩ,1/6W		
	R32	1kΩ,1/6W		
	R33	2kΩ,1/6W		
	C32	33μF,10V		
J1,J2,J3,J4,J5,J6,J8,J9	-	○		
J7,JS2,JS3,JS4,JS5,JS7 JS8,JS9	-	-		
JS6,JS10	-	○		
JS1(R23)	100Ω,1W	○		

(\*1) STK433-040N-E/060N-E/130N-E(2ch Amp) doesn't mount parts of( )

(\*2) Recommended standby circuit is used.

## STK433-000N-E series

### Recommended external components

STK433-040N-E/060N-E/130N-E/330N-E

Parts Location	Recommended value	Circuit purpose	Above Recommended value	Below Recommended value
R01,R23	100Ω/1W	Resistance for Ripple filter. (Fuse resistance is recommended. Ripple filter is constituted with C03, C23.)	Short-through current may decrease at high frequency.	Short-through current may increase at high frequency.
R02,R03,R04	1kΩ	Resistance for input filters.	-	-
R05,R06,R07	56kΩ	Input impedance is determined.	Output neutral voltage(VN) shift. (It is referred that R05=R08, R06=R09)	
R08,R09,R10	56kΩ	Voltage Gain(VG) is determined with R11,R12,R13	-	-
R11,R12,R13	1.8kΩ	Voltage Gain(VG) is determined with R8,R9,R10 (As for VG, it is desirable to set up by R11,R12,R13)	It may oscillate. (Vg > 30dB)	With especially no problem
R14,R15,R16	4.7Ω	Resistance for oscillation prevention.	-	-
R17,R18,R19	4.7Ω/1W	Resistance for oscillation prevention.	-	-
R20,R21,R22	0.22Ω/2W	This resistance is used as detection resistance of the protection circuit application.	Decrease of Maximum output Power	It may cause thermal runaway
R30	Note *5	Select Restriction resistance, for the impression voltage of '#17(Stand-By)pin' must not exceed the maximum rating.		
C01,C02	100μF/50V	Capacitor for oscillation prevention. · Locate near the HIC as much as possible. · Power supply impedance is lowered and stable operation of the IC is carried out. (Electrolytic capacitor is recommended.)	-	-
C03,C23	100μF/50V	Decoupling capacitor · The Ripple ingredient mixed in an input side is removed from a power supply line. (Ripple filter is constituted with R01, R23.)	The change in the Ripple ingredient mixed in an input side from a power supply line	
C04,C05,C06	2.2μF/50V	Input coupling capacitor.(for DC current prevention.)	-	
C07,C08,C09	470pF	Input filter capacitor · A high frequency noise is reduced with the filter constituted by R02,R03,R04	-	
C10,C11,C12	3pF	Capacitor for oscillation prevention.	It may oscillate.	
C13,C14,C15	10μF/10V	Negative feedback capacitor. The cutoff frequency of a low cycle changes. ( $f_L=1/(2\pi \cdot C13 \cdot R11)$ )	The voltage gain(VG) of low frequency is extended. However, the pop noise at the time of a power supply injection also becomes large.	The voltage gain(VG) of low frequency decreases.
C16,C17,C18	0.1μF	Capacitor for oscillation prevention.	It may oscillate.	
C19,C20,C21	100pF(040N-E) 56pF(060N-E) N.C.(130N-E, 330N-E)	Capacitor for oscillation prevention.	It may oscillate.	
L01,L02,L03	3μH	Coil for oscillation prevention.	With especially no problem	It may oscillate.

STK433-000N-E series

PCB Layout example

STK433-840N-E/890N-E

Top view

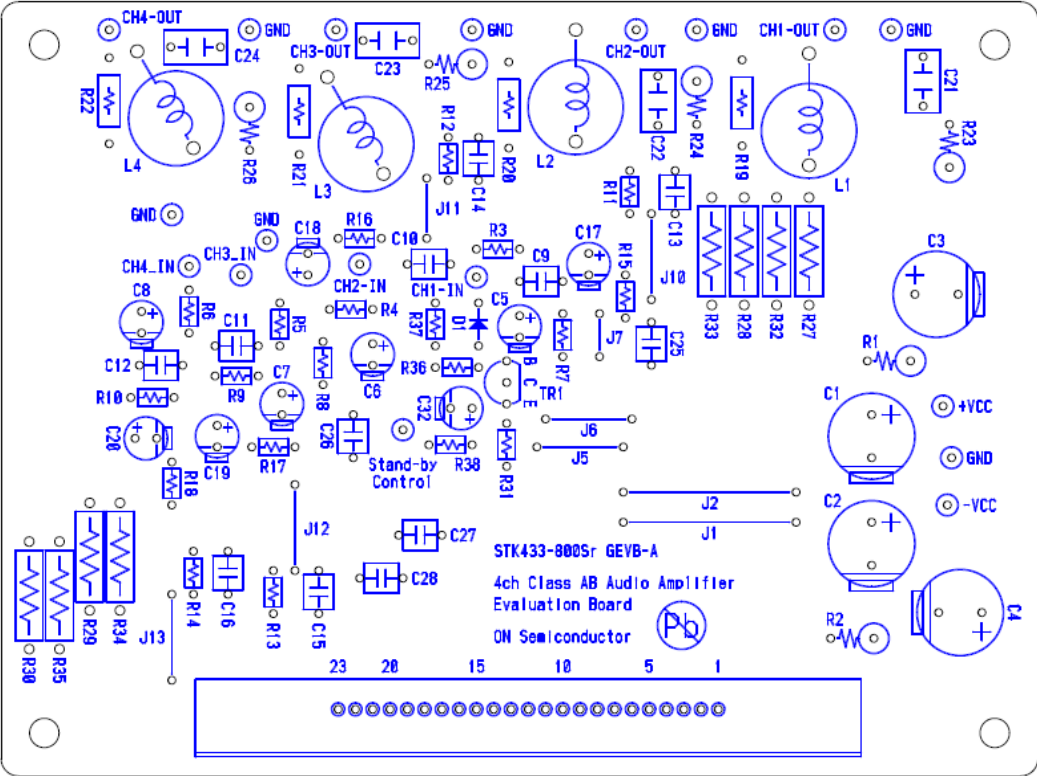

Bottom view

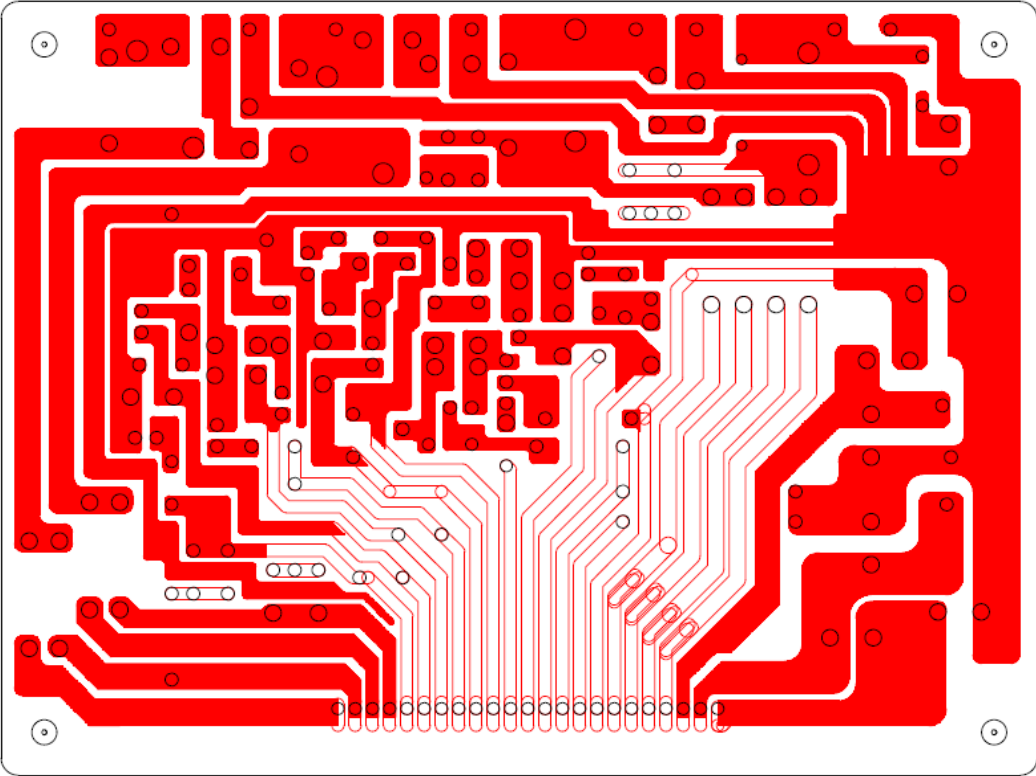

**STK433-800NSr PCB PARTS LIST**

PCB Name : STK433-800Sr GEVB - A

Location No.	RATING	Component
		STK433-840N-E/890N-E
Hybrid IC #1 Pin Position	-	1
R01,R02	100Ω,1W	○
R03,R04,R05,R06	1kΩ,1/6W	○
R07,R08,R09,R10, R11,R12,R13,R14	56KΩ,1/6W	○
R15,R16,R17,R18	1.8KΩ,1/6W	○
R19,R20,R21,R22	4.7Ω,1/4W	○
R23,R24,R25,R26	4.7Ω,1W	○
R27,R28,R29,R30	0.22Ω,5W	○
R32,R33,R34,R35	0.22Ω,5W	-
C01,C02,C03,C04	100μF,100V	○
C05,C06,C07,C08	2.2μF,50V	○
C09,C10,C11,C12	470pF,50V	○
C13,C14,C15,C16	3pF,50V	○
C17,C18,C19,C20	10μF,10V	○
C21,C22,C23,C24	0.1μF,50V	○
C25,C26,C27,C28	100pF,50V	○
L01,L02,L03,L04	3μH	○
Stand-By Control Circuit	Tr1	○
	D1	○
	R31	○
	R32	○
	R33	○
	R34	○
	C32	○
	-	
	-	
	-	
	-	

## STK433-000N-E series

### Recommended external components

#### STK433-840N-E/890N-E

Parts Location	Recommended value	Circuit purpose	Above Recommended value	Below Recommended value
R01,R02	100Ω/1W	Resistance for Ripple filters. (Fuse resistance is recommended. Ripple filter is constituted with C03, C04.)	Short-through current may decrease at high frequency.	Short-through current may increase at high frequency.
R03,R04,R05,R06	1kΩ	Resistance for input filters.	-	-
R07,R08,R09,R10	56kΩ	Input impedance is determined.	Output neutral voltage (VN) shift. (It is referred that R07=R11,R08=R12,R09=R13,R10=R14)	
R11,R12,R13,R14	56kΩ	Voltage Gain(VG) is determined with R15,R16,R17,R18	-	-
R15,R16,R17,R18	1.8kΩ	Voltage Gain (VG) is determined with R11, R12, R13, and R14. (As for VG, it is desirable to set up by R15, R16, R17, and R18.)	It may oscillate. (Vg<30dB)	With especially no problem
R19,R20,R21,R22	4.7Ω	Resistance for oscillation prevention.	-	-
R23,R24,R25,R26	4.7Ω/1W	Resistance for oscillation prevention.	-	-
R27,R28,R29,R30	0.22Ω ±10%,5W	Output emitter resistor (Metal-plate Resistor is recommended.)	Decrease of Maximum output Power	It may cause thermal runaway
R31	Note*4	Select Restriction resistance, for the impression voltage of '#13(Stand-By) pin' must not exceed the maximum rating.		
C01,C02	100μF/100V	Capacitor for oscillation prevention. · Locate near the HIC as much as possible. · Power supply impedance is lowered and stable operation of the IC is carried out. (Electrolytic capacitor is recommended.)	-	-
C03,C04	100μF/100V	Decoupling capacitor · The Ripple ingredient mixed in an input side is removed from a power supply line. (Ripple filter is constituted with R01, R02.)	The change in the Ripple ingredient mixed in an input side from a power supply line	
C05,C06,C07,C08	2.2μF/50V	Input coupling capacitor. (For DC current prevention.)	-	
C09,C10,C11,C12	470pF	Input filter capacitor · A high frequency noise is reduced with the filter constituted by R03, R04, R05, R06.	-	
C13,C14,C15,C16	5pF	Capacitor for oscillation prevention.	It may oscillate.	
C17,C18,C19,C20	10μF/10V	Negative feedback capacitor. · The cutoff frequency of a low cycle changes. (fL=1/(2π · C17 · R15))	The voltage gain (VG) of low frequency is extended. However, the pop noise at the time of a power supply injection also becomes large.	The voltage gain (VG) of low frequency decreases.
C21,C22,C23,C24	0.1μF	Capacitor for oscillation prevention.	It may oscillate.	
C25,C26,C27,C28	100pF	Capacitor for oscillation prevention.	It may oscillate.	
L01,L02,L03,L04	3μH	Coil for oscillation prevention.	With especially no problem	It may oscillate.

Characteristic of Evaluation Board

STK433-040N-E

**THD-Po**  
STK433-040N-E

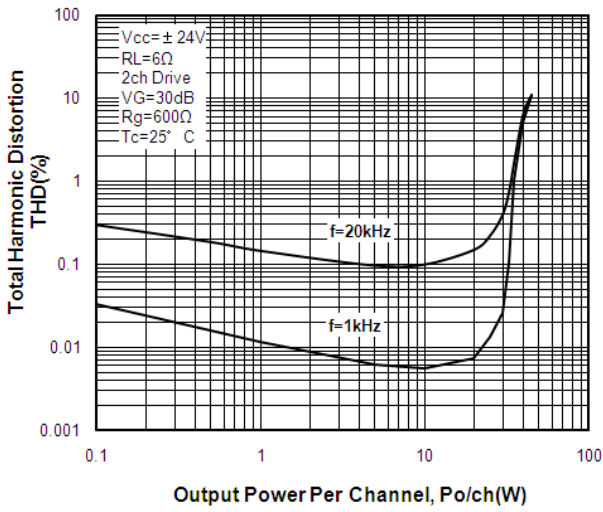

**Pd-Po**  
STK433-040N-E

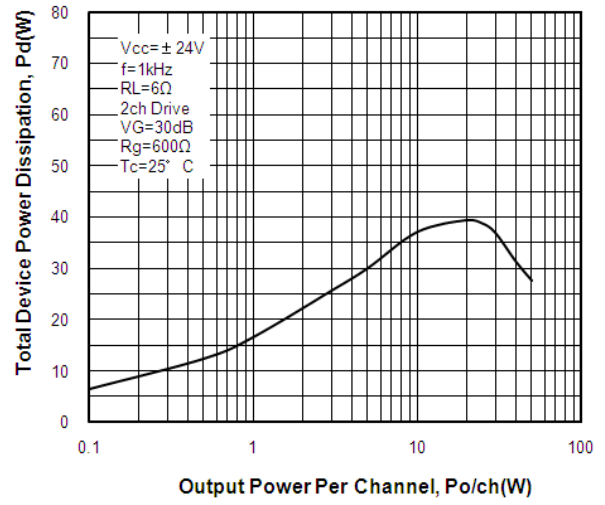

**Po-Vcc**  
STK433-040N-E

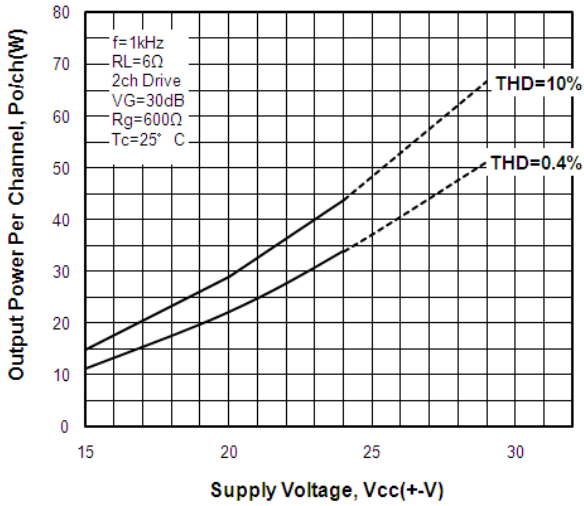

**Po-f**  
STK433-040N-E

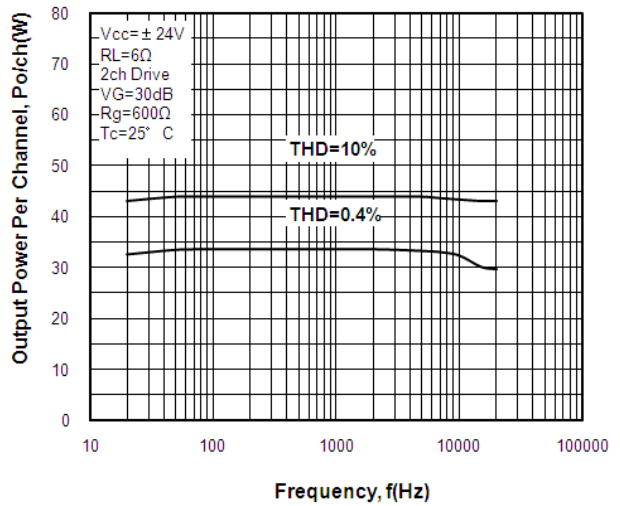





# STK433-000N-E series

## Characteristic of Evaluation Board

STK433-060N-E

**THD-Po**

STK433-060N-E

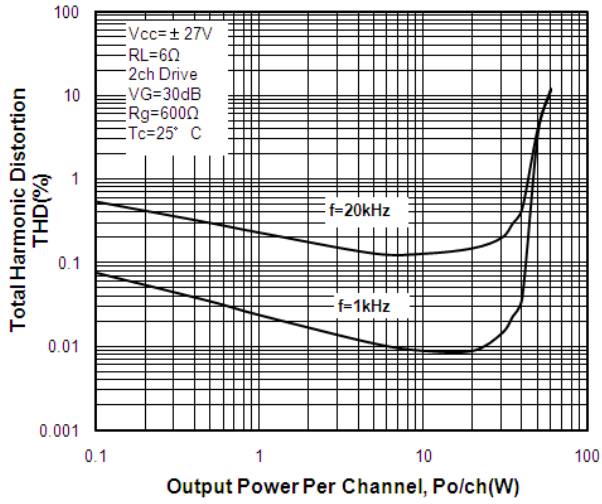

**Pd-Po**

STK433-060N-E

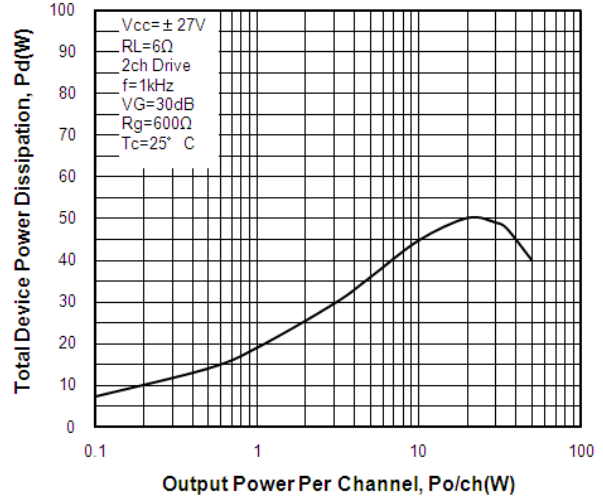

**Po-Vcc**

STK433-060N-E

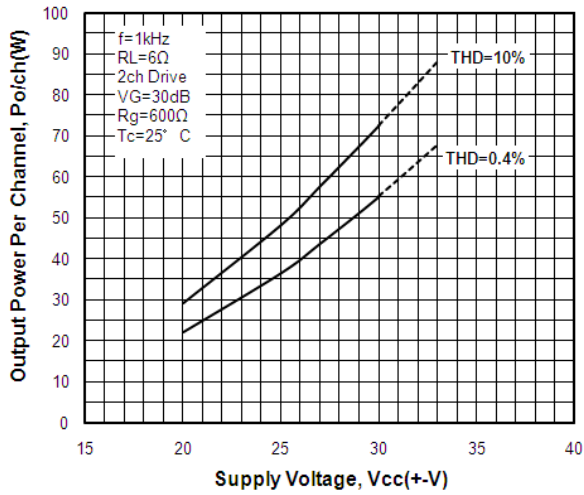

**Po-f**

STK433-060N-E

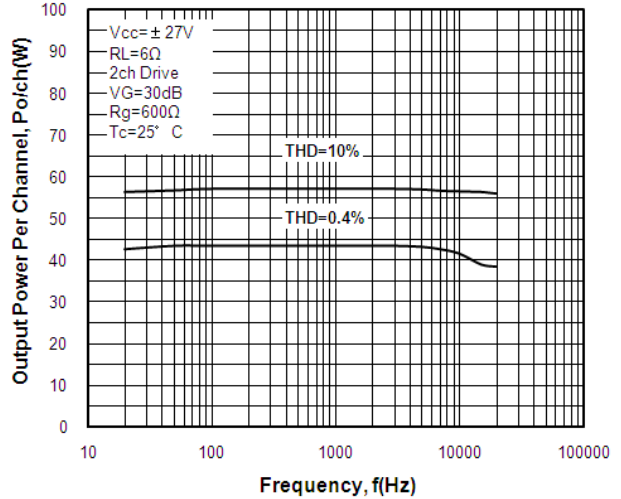

# STK433-000N-E series

## Characteristic of Evaluation Board

STK433-130N-E

**THD-Po**

STK433-130N-E

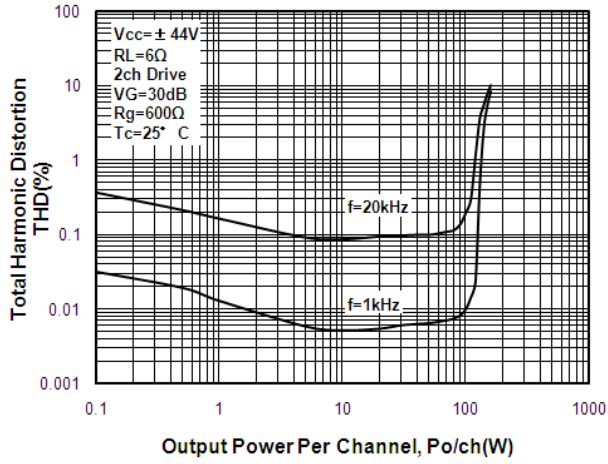

**Pd-Po**

STK433-130N-E

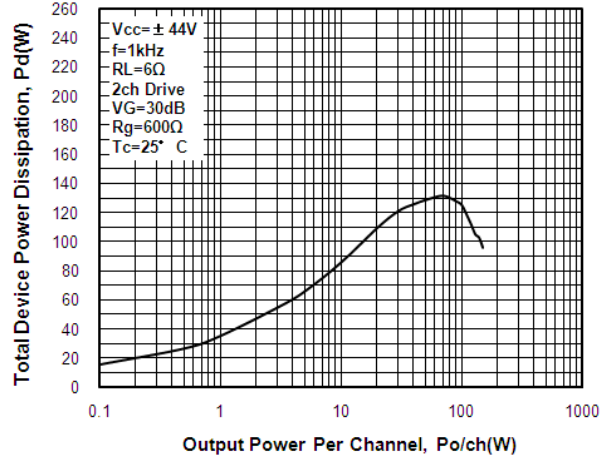

**Po-Vcc**

STK433-130N-E

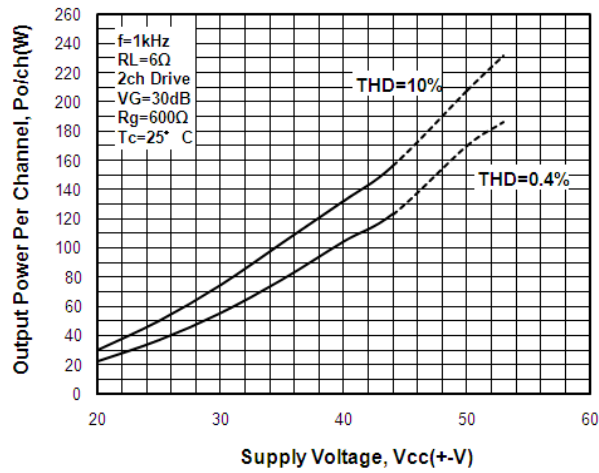

**Po-f**

STK433-130N-E

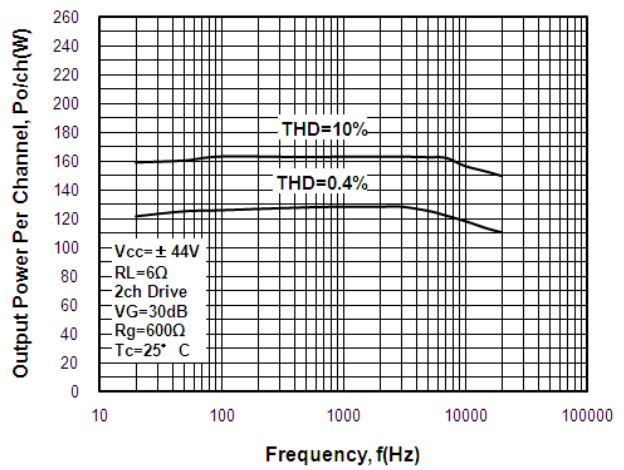

# STK433-000N-E series

## Characteristic of Evaluation Board

STK433-330N-E

**THD-Po**  
STK433-330N-E

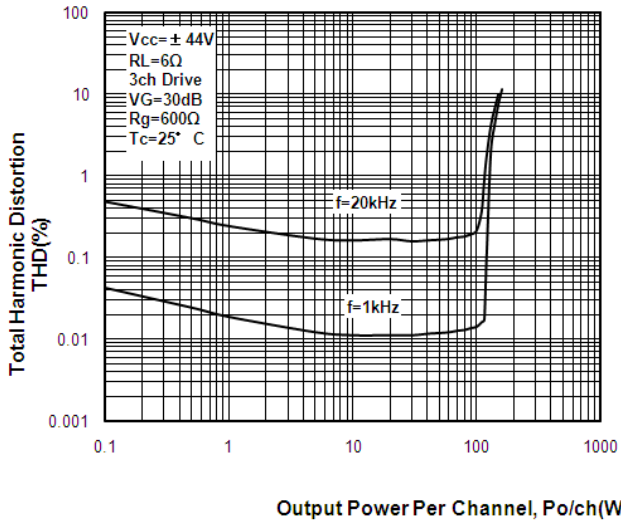

**Pd-Po**  
STK433-330N-E

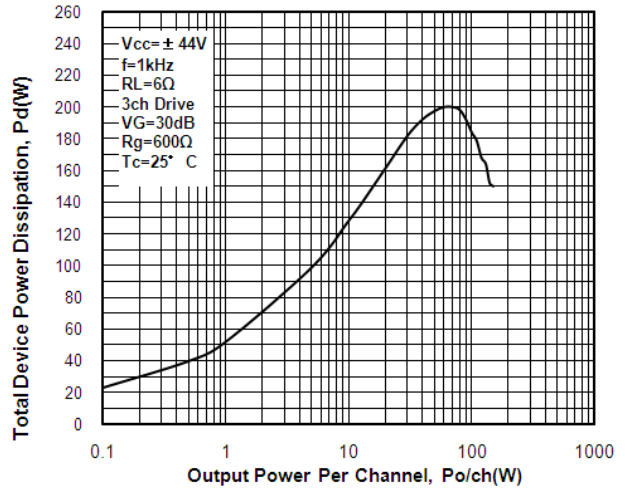

**Po-Vcc**  
STK433-330N-E

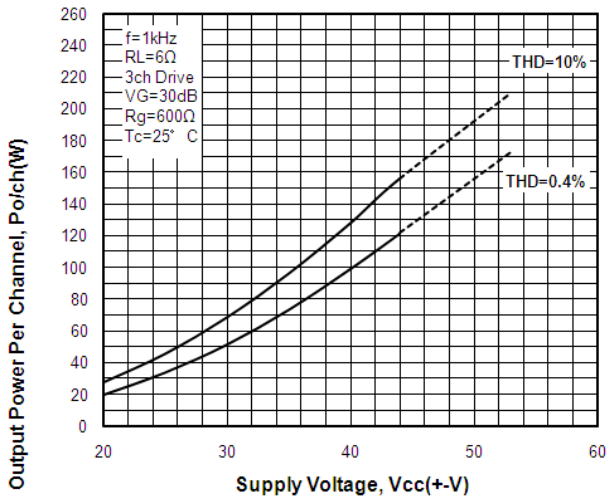

**Po-f**  
STK433-330N-E

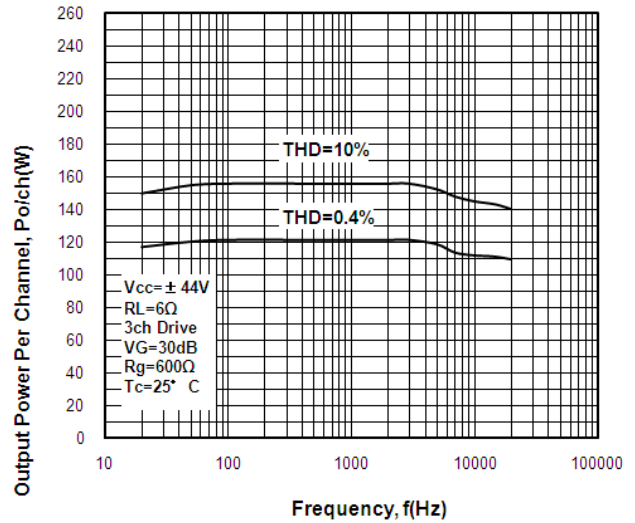

Characteristic of Evaluation Board

STK433-840N-E

**THD-Po**  
STK433-840N-E

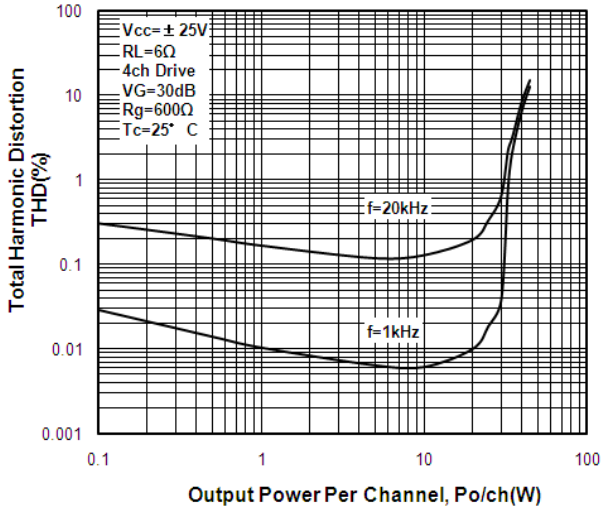

**Pd-Po**  
STK433-840N-E

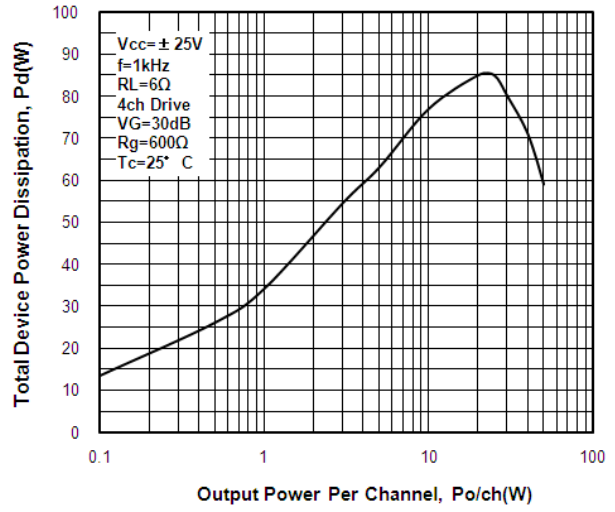

**Po-Vcc**  
STK433-840N-E

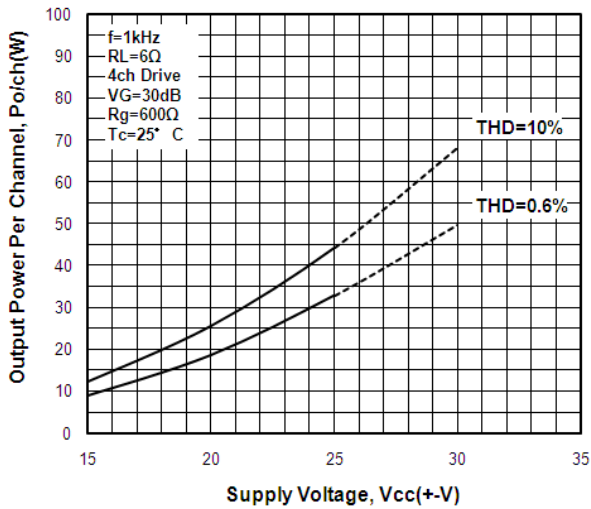

**Po-f**  
STK433-840N-E

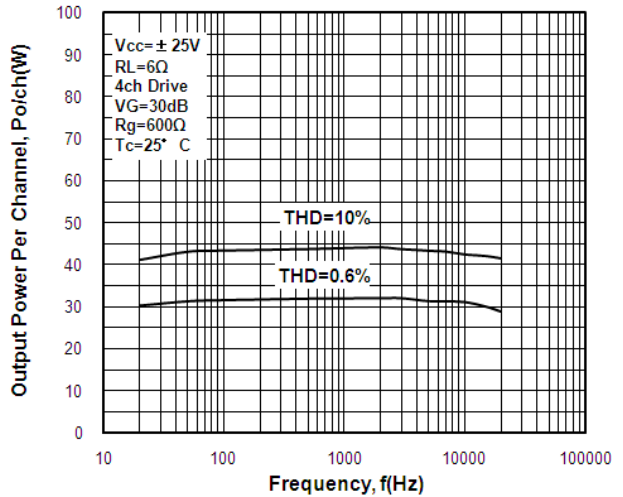

Characteristic of Evaluation Board

STK433-890N-E

**THD-Po**  
STK433-890N-E

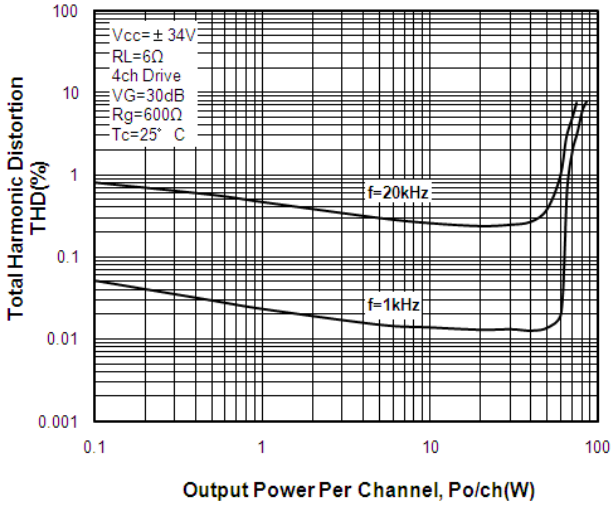

**Pd-Po**  
STK433-890N-E

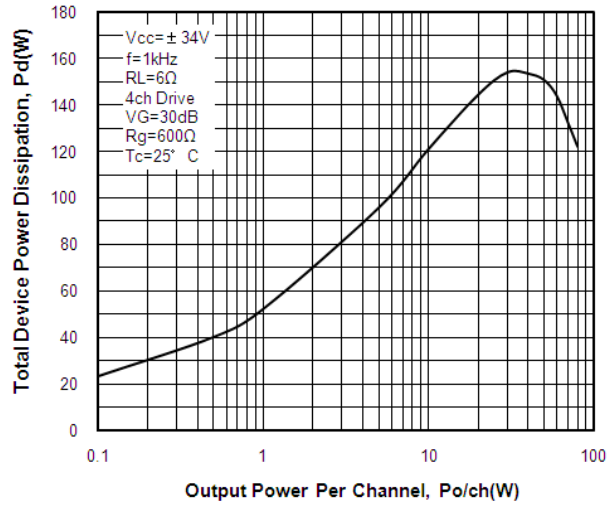

**Po-Vcc**  
STK433-890N-E

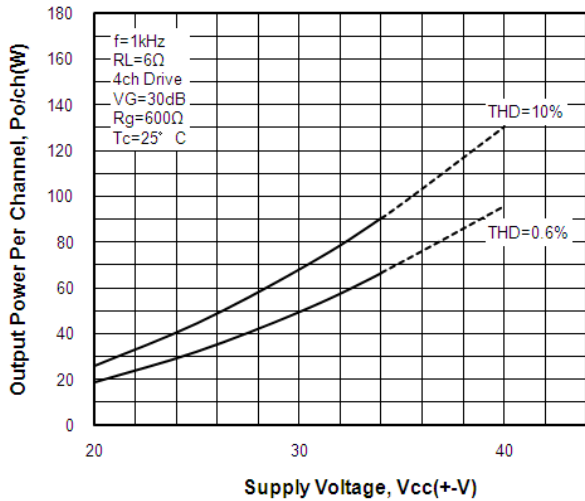

**Po-f**  
STK433-890N-E

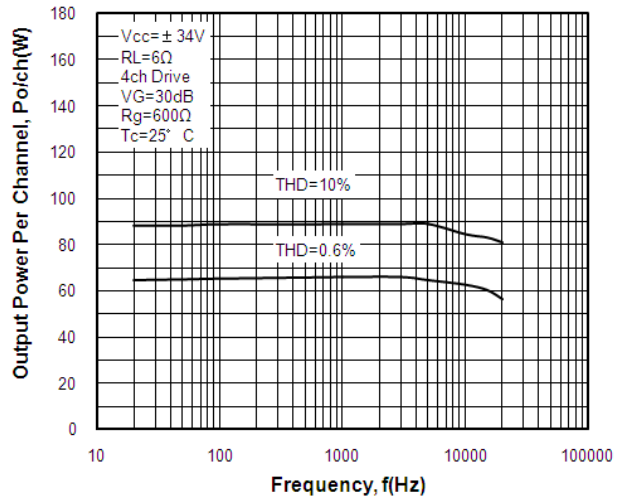

**A Thermal Design Tip For STK433-040N-E Amplifier**

[Thermal Design Conditions]

The thermal resistance ( $\theta_{c-a}$ ) of the heat-sink which manages the heat dissipation inside the Hybrid IC will be determined as follow:

(Condition 1) The case temperature ( $T_c$ ) of the Hybrid IC should not exceed 125°C  

$$P_d \times \theta_{c-a} + T_a < 125^\circ\text{C} \quad \dots\dots (1)$$

Where  $T_a$  : the ambient temperature for the system

(Condition 2) The junction temperature of each power transistor should not exceed 150°C  

$$P_d \times \theta_{c-a} + P_d / N \times \theta_{j-c} + T_a < 150^\circ\text{C} \quad \dots\dots (2)$$

Where  $N$  : the number of transistors (two for 1 channel , ten for channel)

$\theta_{j-c}$  : the thermal resistance of each transistor (see specification)

Note that the power consumption of each power transistor is assumed to be equal to the total power dissipation ( $P_d$ ) divided by the number of transistors ( $N$ ).

From the formula (1) and (2), we will obtain:

$$\theta_{c-a} < (125 - T_a) / P_d \quad \dots\dots (1)'$$

$$\theta_{c-a} < (150 - T_a) / P_d - \theta_{j-c} / N \quad \dots\dots (2)'$$

The value which satisfies above formula (1)' and (2)' will be the thermal resistance for a desired heat-sink.

Note that all of the component except power transistors employed in the Hybrid IC comply with above conditions.

[Example of Thermal Design]

Generally, the power consumption of actual music signals are being estimated by the continuous signal of 1/8  $P_{omax}$ . (Note that the value of 1/8  $P_{omax}$  may be varied from the country to country.)

(Sample of STK433-040N-E ; 25W×2ch)

If  $V_{cc}$  is ±24V, and  $R_L$  is 6Ω, then the total power dissipation ( $P_d$ ) of inside Hybrid IC is as follow;

$$P_d = 26\text{W} \quad (\text{at } 3.13\text{W output power, } 1/8 \text{ of } P_{omax})$$

There are four (4) transistors in Audio Section of this Hybrid IC, and thermal resistance ( $\theta_{j-c}$ ) of each transistor is 4.2°C/W. If the ambient temperature ( $T_a$ ) is guaranteed for 50°C, then the thermal resistance ( $\theta_{c-a}$ ) of a desired heat-sink should be;

$$\begin{aligned} \text{From (1)'} \quad \theta_{c-a} &< (125 - 50) / 26 \\ &< 2.88 \end{aligned}$$

$$\begin{aligned} \text{From (2)'} \quad \theta_{c-a} &< (150 - 50) / 26 - 4.2 / 4 \\ &< 2.79 \end{aligned}$$

Therefore, in order to satisfy both (1)' and (2)', the thermal resistance of a desired Heat-sink will be **2.79°C/W**.

[Note]

Above are reference only. The samples are operated with a constant power supply. Please verify the conditions when your system is actually implemented.

**A Thermal Design Tip For STK433-060N-E Amplifier**

[Thermal Design Conditions]

The thermal resistance ( $\theta_{c-a}$ ) of the heat-sink which manages the heat dissipation inside the Hybrid IC will be determined as follow:

(Condition 1) The case temperature ( $T_c$ ) of the Hybrid IC should not exceed 125°C  

$$P_d \times \theta_{c-a} + T_a < 125^\circ\text{C} \quad \text{..... (1)}$$

Where  $T_a$  : the ambient temperature for the system

(Condition 2) The junction temperature of each power transistor should not exceed 150°C  

$$P_d \times \theta_{c-a} + P_d / N \times \theta_{j-c} + T_a < 150^\circ\text{C} \quad \text{..... (2)}$$

Where  $N$  : the number of transistors (two for 1 channel , ten for channel)

$\theta_{j-c}$  : the thermal resistance of each transistor (see specification)

Note that the power consumption of each power transistor is assumed to be equal to the total power dissipation ( $P_d$ ) divided by the number of transistors ( $N$ ).

From the formula (1) and (2), we will obtain:

$$\theta_{c-a} < (125 - T_a) / P_d \quad \text{..... (1)'}$$

$$\theta_{c-a} < (150 - T_a) / P_d - \theta_{j-c} / N \quad \text{..... (2)'}$$

The value which satisfies above formula (1)' and (2)' will be the thermal resistance for a desired heat-sink.

Note that all of the component except power transistors employed in the Hybrid IC comply with above conditions.

[Example of Thermal Design]

Generally, the power consumption of actual music signals are being estimated by the continuous signal of 1/8  $P_{omax}$ . (Note that the value of 1/8  $P_{omax}$  may be varied from the country to country.)

(Sample of STK433-060N-E ; 35W×2ch)

If  $V_{cc}$  is ±27V, and  $R_L$  is 6Ω, then the total power dissipation ( $P_d$ ) of inside Hybrid IC is as follow;

$$P_d = 33\text{W} \quad (\text{at } 4.375\text{W output power, } 1/8 \text{ of } P_{omax})$$

There are four (4) transistors in Audio Section of this Hybrid IC, and thermal resistance ( $\theta_{j-c}$ ) of each transistor is 3.5°C/W. If the ambient temperature ( $T_a$ ) is guaranteed for 50°C, then the thermal resistance ( $\theta_{c-a}$ ) of a desired heat-sink should be;

$$\begin{aligned} \text{From(1)' } \theta_{c-a} &< (125 - 50) / 33 \\ &< 2.27 \end{aligned}$$

$$\begin{aligned} \text{From(2)' } \theta_{c-a} &< (150 - 50) / 33 - 3.5 / 4 \\ &< 2.16 \end{aligned}$$

Therefore, in order to satisfy both (1)' and (2)', the thermal resistance of a desired Heat-sink will be **2.16°C/W**.

[Note]

Above are reference only. The samples are operated with a constant power supply. Please verify the conditions when your system is actually implemented.

**A Thermal Design Tip For STK433-130N-E Amplifier**

[Thermal Design Conditions]

The thermal resistance ( $\theta_{c-a}$ ) of the heat-sink which manages the heat dissipation inside the Hybrid IC will be determined as follow:

(Condition 1) The case temperature ( $T_c$ ) of the Hybrid IC should not exceed 125°C  

$$P_d \times \theta_{c-a} + T_a < 125^\circ\text{C} \quad \text{..... (1)}$$

Where  $T_a$  : the ambient temperature for the system

(Condition 2) The junction temperature of each power transistor should not exceed 150°C  

$$P_d \times \theta_{c-a} + P_d / N \times \theta_{j-c} + T_a < 150^\circ\text{C} \quad \text{..... (2)}$$

Where  $N$  : the number of transistors (two for 1 channel , ten for channel)

$\theta_{j-c}$  : the thermal resistance of each transistor (see specification)

Note that the power consumption of each power transistor is assumed to be equal to the total power dissipation ( $P_d$ ) divided by the number of transistors ( $N$ ).

From the formula (1) and (2), we will obtain:

$$\theta_{c-a} < (125 - T_a) / P_d \quad \text{..... (1)'}$$

$$\theta_{c-a} < (150 - T_a) / P_d - \theta_{j-c} / N \quad \text{..... (2)'}$$

The value which satisfies above formula (1)' and (2)' will be the thermal resistance for a desired heat-sink.

Note that all of the component except power transistors employed in the Hybrid IC comply with above conditions.

[Example of Thermal Design]

Generally, the power consumption of actual music signals are being estimated by the continuous signal of 1/8  $P_{omax}$ . (Note that the value of 1/8  $P_{omax}$  may be varied from the country to country.)

(Sample of STK433-130N-E ; 100W×2ch)

If  $V_{cc}$  is ±44V, and  $R_L$  is 6Ω, then the total power dissipation ( $P_d$ ) of inside Hybrid IC is as follow;

$$P_d = 91\text{W} \quad (\text{at } 12.5\text{W output power, } 1/8 \text{ of } P_{omax})$$

There are four (4) transistors in Audio Section of this Hybrid IC, and thermal resistance ( $\theta_{j-c}$ ) of each transistor is 1.6°C/W. If the ambient temperature ( $T_a$ ) is guaranteed for 50°C, then the thermal resistance ( $\theta_{c-a}$ ) of a desired heat-sink should be;

$$\begin{aligned} \text{From (1)' } \theta_{c-a} &< (125 - 50) / 91 \\ &< 0.82 \end{aligned}$$

$$\begin{aligned} \text{From (2)' } \theta_{c-a} &< (150 - 50) / 91 - 1.6 / 4 \\ &< 0.70 \end{aligned}$$

Therefore, in order to satisfy both (1)' and (2)', the thermal resistance of a desired Heat-sink will be **0.70°C/W**.

[Note]

Above are reference only. The samples are operated with a constant power supply. Please verify the conditions when your system is actually implemented.



**A Thermal Design Tip For STK433-330N-E Amplifier**

[Thermal Design Conditions]

The thermal resistance ( $\theta_{c-a}$ ) of the heat-sink which manages the heat dissipation inside the Hybrid IC will be determined as follow:

(Condition 1) The case temperature ( $T_c$ ) of the Hybrid IC should not exceed 125°C  

$$P_d \times \theta_{c-a} + T_a < 125^\circ\text{C} \quad \text{..... (1)}$$

Where  $T_a$  : the ambient temperature for the system

(Condition 2) The junction temperature of each power transistor should not exceed 150°C  

$$P_d \times \theta_{c-a} + P_d / N \times \theta_{j-c} + T_a < 150^\circ\text{C} \quad \text{..... (2)}$$

Where  $N$  : the number of transistors (two for 1 channel , ten for channel)

$\theta_{j-c}$  : the thermal resistance of each transistor (see specification)

Note that the power consumption of each power transistor is assumed to be equal to the total power dissipation ( $P_d$ ) divided by the number of transistors ( $N$ ).

From the formula (1) and (2), we will obtain:

$$\theta_{c-a} < (125 - T_a) / P_d \quad \text{..... (1)'}$$

$$\theta_{c-a} < (150 - T_a) / P_d - \theta_{j-c} / N \quad \text{..... (2)'}$$

The value which satisfies above formula (1)' and (2)' will be the thermal resistance for a desired heat-sink.

Note that all of the component except power transistors employed in the Hybrid IC comply with above conditions.

[Example of Thermal Design]

Generally, the power consumption of actual music signals are being estimated by the continuous signal of 1/8  $P_{omax}$ . (Note that the value of 1/8  $P_{omax}$  may be varied from the country to country.)

(Sample of STK433-330N-E ; 100W×3ch)

If  $V_{cc}$  is ±44V, and  $R_L$  is 6Ω, then the total power dissipation ( $P_d$ ) of inside Hybrid IC is as follow;

$$P_d = 139\text{W} \quad (\text{at } 12.5\text{W output power, } 1/8 \text{ of } P_{omax})$$

There are six (6) transistors in Audio Section of this Hybrid IC, and thermal resistance ( $\theta_{j-c}$ ) of each transistor is 1.6°C/W. If the ambient temperature ( $T_a$ ) is guaranteed for 50°C, then the thermal resistance ( $\theta_{c-a}$ ) of a desired heat-sink should be;

$$\begin{aligned} \text{From (1)' } \theta_{c-a} &< (125 - 50) / 139 \\ &< 0.54 \end{aligned}$$

$$\begin{aligned} \text{From (2)' } \theta_{c-a} &< (150 - 50) / 139 - 1.6 / 6 \\ &< 0.45 \end{aligned}$$

Therefore, in order to satisfy both (1)' and (2)', the thermal resistance of a desired Heat-sink will be **0.45°C/W**.

[Note]

Above are reference only. The samples are operated with a constant power supply. Please verify the conditions when your system is actually implemented.

**A Thermal Design Tip For STK433-840N-E Amplifier**

[Thermal Design Conditions]

The thermal resistance ( $\theta_{c-a}$ ) of the heat-sink which manages the heat dissipation inside the Hybrid IC will be determined as follow:

(Condition 1) The case temperature ( $T_c$ ) of the Hybrid IC should not exceed 125°C  

$$P_d \times \theta_{c-a} + T_a < 125^\circ\text{C} \quad \dots\dots (1)$$

Where  $T_a$  : the ambient temperature for the system

(Condition 2) The junction temperature of each power transistor should not exceed 150°C  

$$P_d \times \theta_{c-a} + P_d / N \times \theta_{j-c} + T_a < 150^\circ\text{C} \quad \dots\dots (2)$$

Where  $N$  : the number of transistors (two for 1 channel , ten for channel)

$\theta_{j-c}$  : the thermal resistance of each transistor (see specification)

Note that the power consumption of each power transistor is assumed to be equal to the total power dissipation ( $P_d$ ) divided by the number of transistors ( $N$ ).

From the formula (1) and (2), we will obtain:

$$\theta_{c-a} < (125 - T_a) / P_d \quad \dots\dots (1)'$$

$$\theta_{c-a} < (150 - T_a) / P_d - \theta_{j-c} / N \quad \dots\dots (2)'$$

The value which satisfies above formula (1)' and (2)' will be the thermal resistance for a desired heat-sink.

Note that all of the component except power transistors employed in the Hybrid IC comply with above conditions.

[Example of Thermal Design]

Generally, the power consumption of actual music signals are being estimated by the continuous signal of 1/8  $P_{omax}$ . (Note that the value of 1/8  $P_{omax}$  may be varied from the country to country.)

(Sample of STK433-840N-E ; 25W×4ch)

If  $V_{cc}$  is  $\pm 25V$ , and  $R_L$  is  $6\Omega$ , then the total power dissipation ( $P_d$ ) of inside Hybrid IC is as follow;

$$P_d = 55.0W \text{ (at } 3.125W \text{ output power, } 1/8 \text{ of } P_{omax})$$

There are eight (8) transistors in Audio Section of this Hybrid IC, and thermal resistance ( $\theta_{j-c}$ ) of each transistor is 4.2°C/W. If the ambient temperature ( $T_a$ ) is guaranteed for 50°C, then the thermal resistance ( $\theta_{c-a}$ ) of a desired heat-sink should be;

$$\begin{aligned} \text{From (1)'} \quad \theta_{c-a} &< (125 - 50) / 55.0 \\ &< 1.36 \end{aligned}$$

$$\begin{aligned} \text{From (2)'} \quad \theta_{c-a} &< (150 - 50) / 55.0 - 4.2 / 8 \\ &< 1.29 \end{aligned}$$

Therefore, in order to satisfy both (1)' and (2)', the thermal resistance of a desired Heat-sink will be **1.29°C/W**.

[Note]

Above are reference only. The samples are operated with a constant power supply. Please verify the conditions when your system is actually implemented.

**A Thermal Design Tip For STK433-890N-E Amplifier**

[Thermal Design Conditions]

The thermal resistance ( $\theta_{c-a}$ ) of the heat-sink which manages the heat dissipation inside the Hybrid IC will be determined as follow:

(Condition 1) The case temperature ( $T_c$ ) of the Hybrid IC should not exceed 125°C  

$$P_d \times \theta_{c-a} + T_a < 125^\circ\text{C} \quad \text{..... (1)}$$

Where  $T_a$  : the ambient temperature for the system

(Condition 2) The junction temperature of each power transistor should not exceed 150°C  

$$P_d \times \theta_{c-a} + P_d / N \times \theta_{j-c} + T_a < 150^\circ\text{C} \quad \text{..... (2)}$$

Where  $N$  : the number of transistors (two for 1 channel , ten for channel)

$\theta_{j-c}$  : the thermal resistance of each transistor (see specification)

Note that the power consumption of each power transistor is assumed to be equal to the total power dissipation ( $P_d$ ) divided by the number of transistors ( $N$ ).

From the formula (1) and (2), we will obtain:

$$\theta_{c-a} < (125 - T_a) / P_d \quad \text{..... (1)'}$$

$$\theta_{c-a} < (150 - T_a) / P_d - \theta_{j-c} / N \quad \text{..... (2)'}$$

The value which satisfies above formula (1)' and (2)' will be the thermal resistance for a desired heat-sink.

Note that all of the component except power transistors employed in the Hybrid IC comply with above conditions.

[Example of Thermal Design]

Generally, the power consumption of actual music signals are being estimated by the continuous signal of 1/8  $P_{omax}$ . (Note that the value of 1/8  $P_{omax}$  may be varied from the country to country.)

(Sample of STK433-890N-E ; 50W×4ch)

If  $V_{cc}$  is  $\pm 34V$ , and  $R_L$  is  $6\Omega$ , then the total power dissipation ( $P_d$ ) of inside Hybrid IC is as follow;

$$P_d = 99.0W \text{ (at } 6.25W \text{ output power, } 1/8 \text{ of } P_{omax})$$

There are eight (8) transistors in Audio Section of this Hybrid IC, and thermal resistance ( $\theta_{j-c}$ ) of each transistor is 2.1°C/W. If the ambient temperature ( $T_a$ ) is guaranteed for 50°C, then the thermal resistance ( $\theta_{c-a}$ ) of a desired heat-sink should be;

$$\begin{aligned} \text{From (1)' } \theta_{c-a} &< (125 - 50) / 99.0 \\ &< 0.76 \end{aligned}$$

$$\begin{aligned} \text{From (2)' } \theta_{c-a} &< (150 - 50) / 99.0 - 2.1 / 8 \\ &< 0.75 \end{aligned}$$

Therefore, in order to satisfy both (1)' and (2)', the thermal resistance of a desired Heat-sink will be **0.75°C/W**.

[Note]

Above are reference only. The samples are operated with a constant power supply. Please verify the conditions when your system is actually implemented.

# STK433-000N-E series

## STK433-000N-E/100N-E series Stand-by Control & Mute Control & Load-Short Protection Application

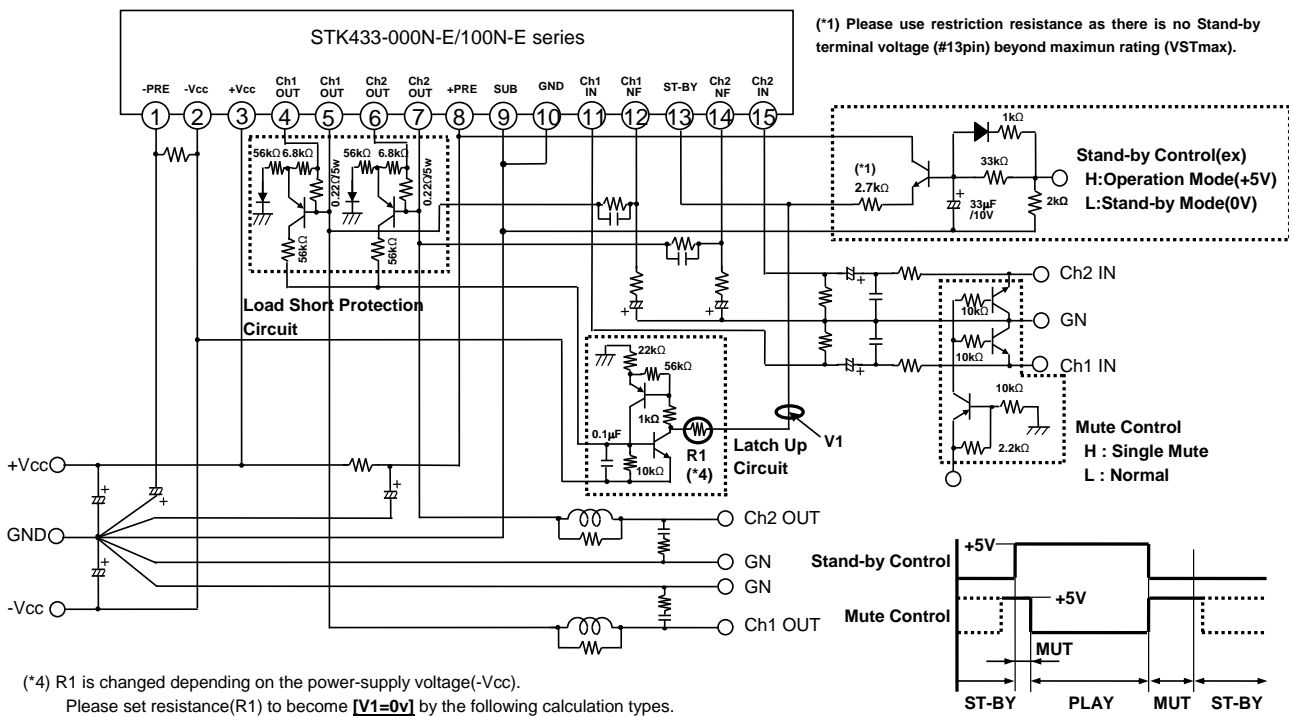

### [ STK433-000N-E/100N-E series Stand-By Control example ]

2012.3.26

#### [Feature]

- The pop noise which occurs to the time of power supply on/off can be improved substantially by recommendation Stand-By Control Application.
- Stand-By Control can be done by additionally adjusting the limitation resistance to the voltage such as miccom, the set design is easy.

(Reference circuit) STK433-000N-E/100N-E series test circuit To Stand-By Control added +5V.

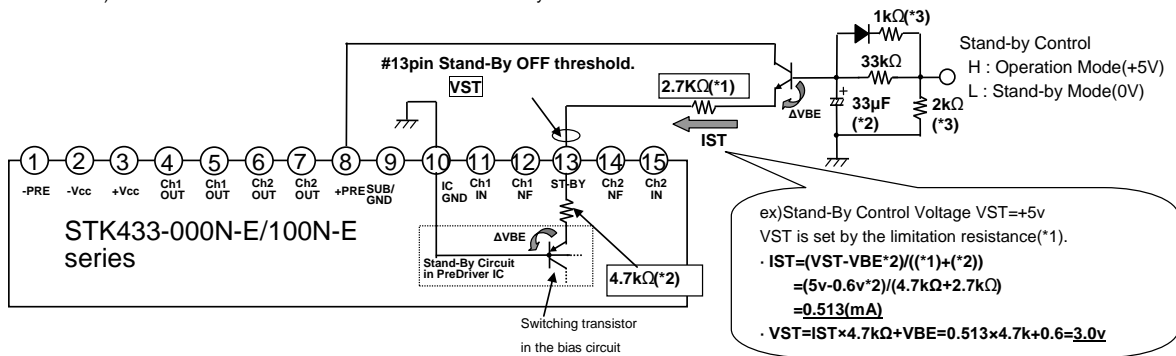

#### [Operation explanation] #13pin Stand-By Control Voltage VST

##### (1) Operation Mode

The switching transistor in the bias circuit turns on and places the amplifier into the operating mode, when 13pin(VST) voltage added above 2.5V(typ3.0V).

##### (2) Stand-By Mode

When 13pin(VST) voltage is stopped (=0V), the switching transistor in the bias circuit turn off. placing the amplifier into the standby mode.

(\*1) The current limiting resistor must be used to ensure that stand-by pin(13pin) voltage does not exceed its maximum rated value VST max.

(\*2) The pop noise level when the power is turned on can be reduced by setting the time constant with a capacitor in operating mode.

(\*3) Determines the time constant at which the capacitor (\*2) is discharged in stand-by mode.

# STK433-00N-E series

## STK433-300series Stand-by Control & Mute Control & Load-Short Protection Application 2009.01.23

(\*1)The impression voltage of a Stand-by terminal(#13) is the maximum rating(VSTmax).Please set up not to exceed.

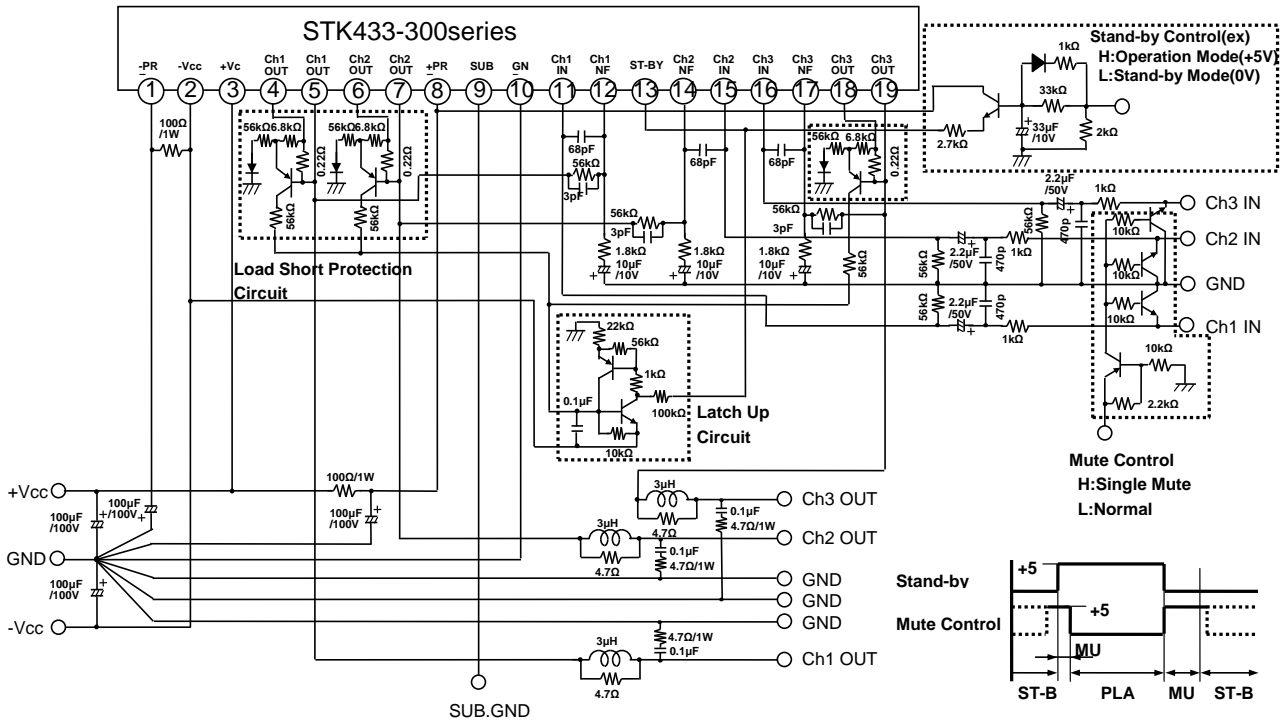

### [ STK433-300 series Stand-By Control example ]

2010.06.14

#### [Feature]

- The pop noise generated when power supply ON/OFF by using recommendation Stand-By Control Application can be improved.
- Stand-By Control can be done by additionally adjusting the limitation resistance (\*1) to the voltage such as Micro computer, the set design is easy.

(Reference circuit) STK433-300series test circuit To Stand-By Control added +5V.

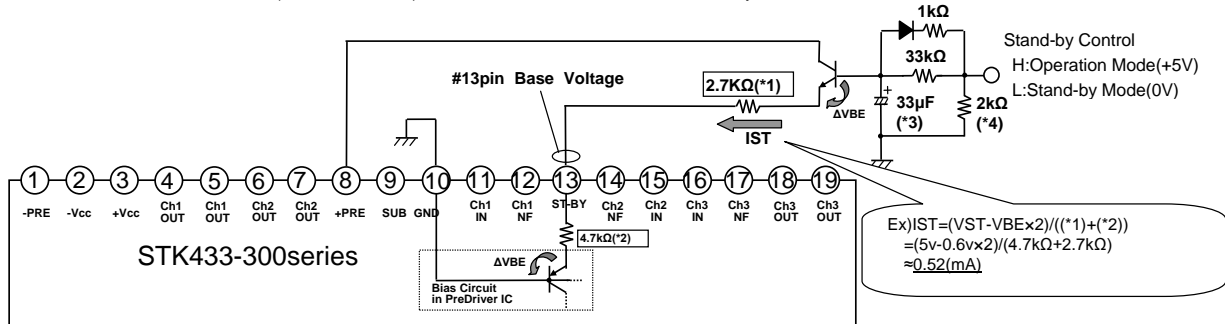

#### [Operation explanation]

1) #13pin Stand-By Control Voltage VST

##### •Operation Mode

SW transistor of Stand-By Circuit is turned on when VST=2.5V or more is impressed, and the power amplifier works.

ex) VST=2.5V

$$V_{ST} = (*2) \times I_{ST} + 0.6\text{V} \rightarrow 2.5\text{V} = 4.7\text{k}\Omega \times I_{ST} + 0.6\text{V} \quad \text{Therefore, } I_{ST} \approx 0.40\text{mA}$$

##### •Stand-By Mode

VST ≤ 0.6V or less turns off the SW transistor of Stand-By Circuit by (typ 0V), and the amplifier stops.

ex) VST=0.6V

$$V_{ST} = (*2) \times I_{ST} + 0.6\text{V} \rightarrow 0.6\text{V} = 4.7\text{k}\Omega \times I_{ST} + 0.6\text{V} \quad \text{Therefore, } I_{ST} \approx 0\text{mA}$$

(\*3)When the power supply is turned on by giving the time constant with the capacitor(\*3) when the amplifier works, the pop noise is improved.

(\*4)When capacitor(\*3) is discharged when the amplifier operation stops, the constant is decided.

# STK433-00N-E series

## STK433-800series Stand-by Control & Mute Control Application

2008.12.18

(\*1)The impression voltage of a Stand-by terminal(#13) is the maximum rating(VSTmax). Please set up not to exceed.

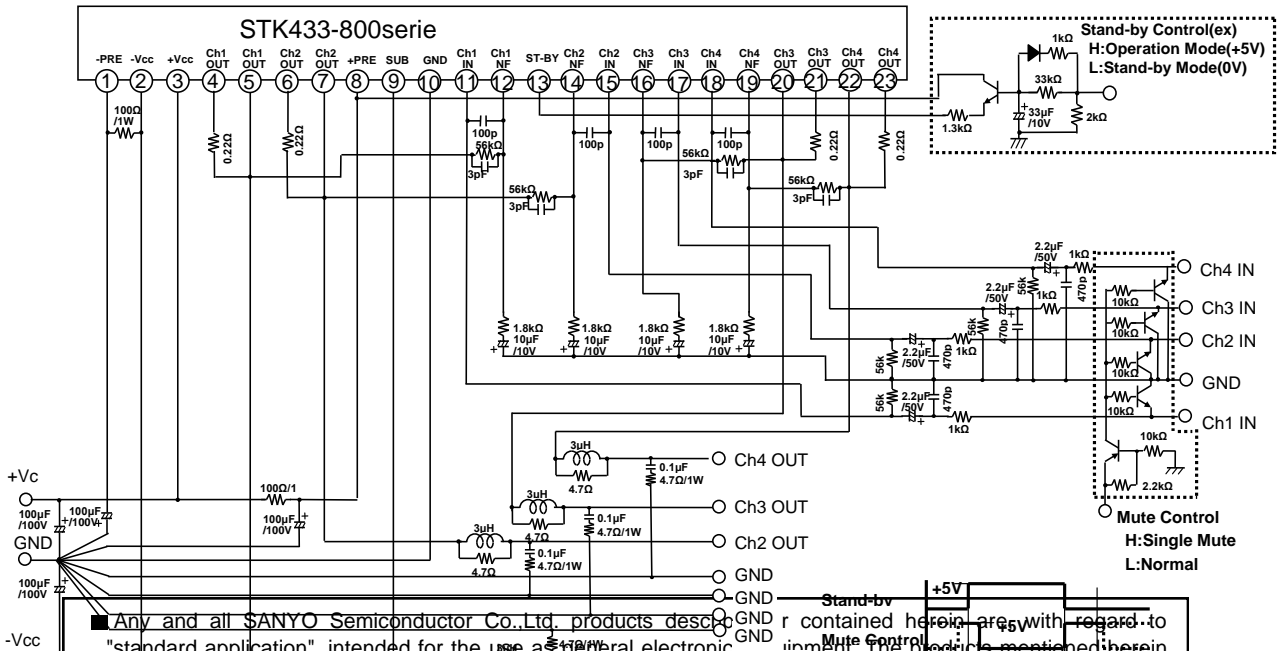

Any and all SANYO Semiconductor Co.,Ltd. products described or contained herein are with regard to "standard application", intended for the use as general electronic instrument. The products mentioned herein shall not be intended for use for any "special application" (medical equipment whose purpose is to sustain life, aerospace instrument, nuclear device, burning appliances, transportation machinery, traffic signal system, safety equipment etc.) that shall require extremely high level of reliability and can directly threaten human lives in case of failure or malfunction of the product or may cause harm to human bodies, nor shall they grant any guarantee thereof. If you should intend to use our products for new introduction or other application different from current conditions on the usage of automotive device, communication device, office equipment, industrial equipment etc., please consult with us about usage condition (temperature, operation time etc.) prior to the intended use, or contact us by e-mail or inquiry before the intended use, our customer shall be solely responsible for the use.

[Feature] Specifications of any and all SANYO Semiconductor Co.,Ltd. products described or contained herein stipulate the performance, characteristics, and functions of the described products in the model shown state, and are not guarantees of the performance, characteristics, and functions of the described products as mounted in the customer's products or equipment. To verify symptoms and states that cannot be evaluated in an independent device, the customer should always evaluate and test devices mounted in the customer's products or equipment.

SANYO Semiconductor Co.,Ltd. assumes no responsibility for equipment failures that result from using products at values that exceed, even momentarily, rated values (such as maximum ratings, operating condition ranges, or other parameters) listed in products specifications of any and all SANYO Semiconductor Co.,Ltd. products described or contained herein. However, any and all semiconductor products or malfunction with some probability. It is possible that the malfunction could give rise to accidents or events that could endanger human lives, or to small accidents or events that could cause damage to other property. When designing equipment, refer to the "Delivery Specification" for the STK433-800series at could cause damage to other property. When design safety measures so that these kinds of accidents or events cannot occur. Such measures should be limited to protective circuits and error prevention circuits for safe design, redundancy design, etc.

Ex) Stand-By Control Voltage  $V_{ST}=+5V$   
 $V_{ST}$  is set by the limitation resistance(\*1).  
 $I_{ST}=(V_{ST}-V_{BE} \times 2)/((R1)+(R2))$   
 $= (5V - 0.6V \times 2) / (2.2k\Omega + 1.3k\Omega)$   
 $\approx 1.09(mA)$

[Operation explanation] In the event that any or all SANYO Semiconductor Co.,Ltd. products described or contained herein are controlled under any of applicable local export control laws and regulations, such products may require the export license from the authorities concerned in accordance with the applicable laws.  
 ex) VST=30V  
 $V_{ST}=(I_{ST} \times (R1+R2)) + V_{BE} \times 2 = 3.0V = 2.2k\Omega \times I_{ST} + 0.6V$  Therefore,  $I_{ST} \approx 1.09mA$   
 Stand-By Mode  
 $V_{ST} = 0.6V$  or less turns off the SW transistor of Stand-By Circuit by (typ 0v), and the amplifier stops.  
 ex) VST=0.6V  
 $V_{ST}=(I_{ST} \times (R1+R2)) + V_{BE} \times 2$

(\*3)When using the technical information of products described herein, neither warranty nor license shall be granted with respect to the product or the product's performance.  
 (\*4)When copyright is secured in the product or the product's performance, SANYO Semiconductor Co.,Ltd. or any third party. SANYO Semiconductor Co.,Ltd. shall not be liable for any claim or suits with regard to a third party's intellectual property rights which has resulted from the use of the technical information and products mentioned above.

This catalog provides information as of April, 2012. Specifications and information herein are subject to change without notice.

